

SYSTÈME AÉRAULIQUE

# NOTICE D'INSTALLATION

MANUAL - ISTRUZIONI - ANLEITUNG - INSTRUÇÕES - INSTRUCȚIIS

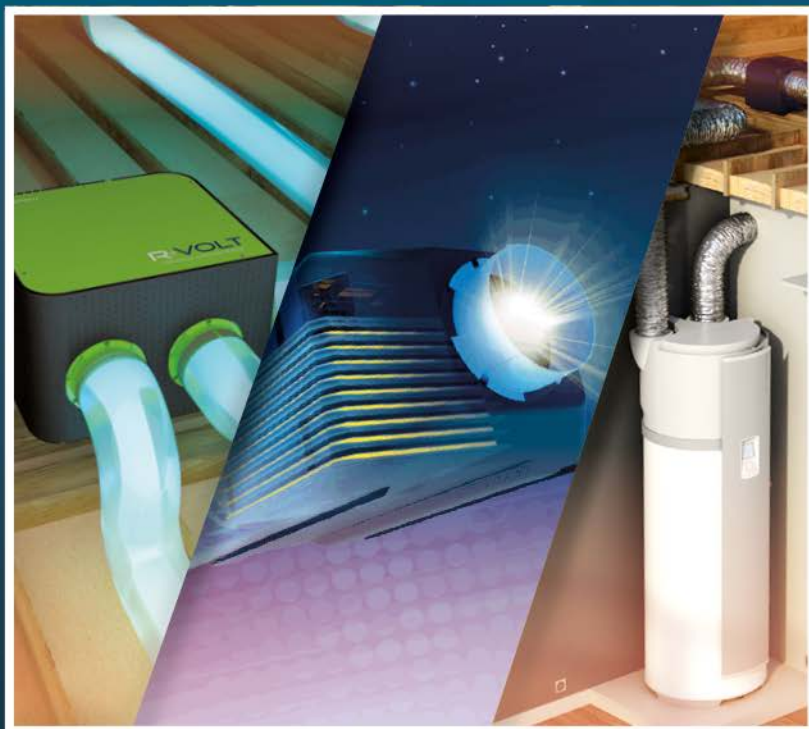

MODUL-R











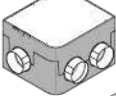

STOCK-R

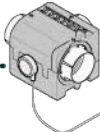
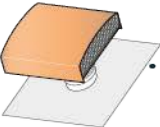
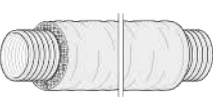
PAC-O

**i**

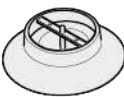
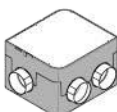
	.....	10
	.....	11
	.....	12
	.....	13



<b>1</b>		.....	14
<b>2</b>		.....	18
<b>3</b>		.....	24
<b>4</b>		.....	26
<b>5</b>		.....	30
<b>6</b>		.....	32
<b>7</b>	    	.....	36
<b>8</b>		.....	40
<b>9</b>	   	.....	42
<b>10</b>		.....	45



**11** ..... 46

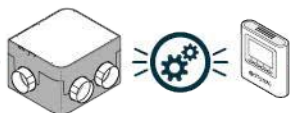

CODE

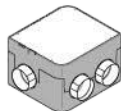

Modul-R  
Modul-AIR

48



**12** ..... 50



**1**



52

**15**



56

**2**



53

**16**



57

**3**



54

**17**



58

**4**



55

**24**



59



**13** ..... 60



..... 61

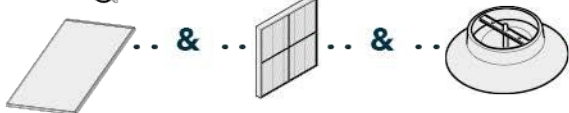

**i** — SYSTEME / SYSTEM

**A**

R-VOLT / R-VOLT PLUS  
AIR-VOLT / AIR-VOLT PLUS

R-VOLT PLUS / R-VOLT PLUS  
AIR-VOLT PLUS / AIR-VOLT PLUS

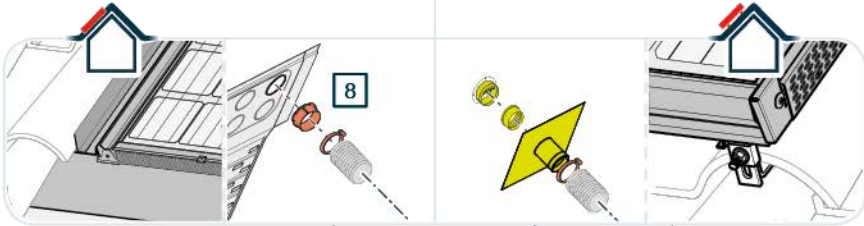

Code produit  
Product code  
Produktcode  
Productcode  
Codice prodotto  
Código do produto

**2**

Réglage usine **✓ OK**  
Factory settings  
Werkseinstellungen  
fabrieksinstellingen  
condizioni iniziali  
Regulamento fabrica

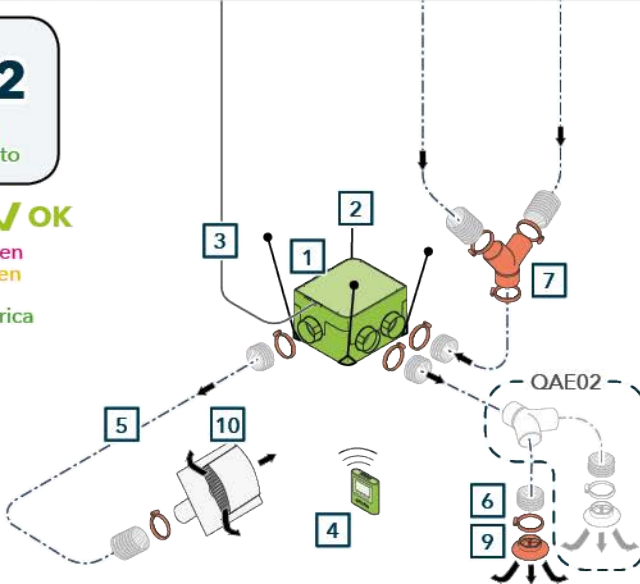

 MAVEIS05

 QAE09T

 QAE11

 QAE13

 OPTION

R-VOLT  
AIR-VOLT

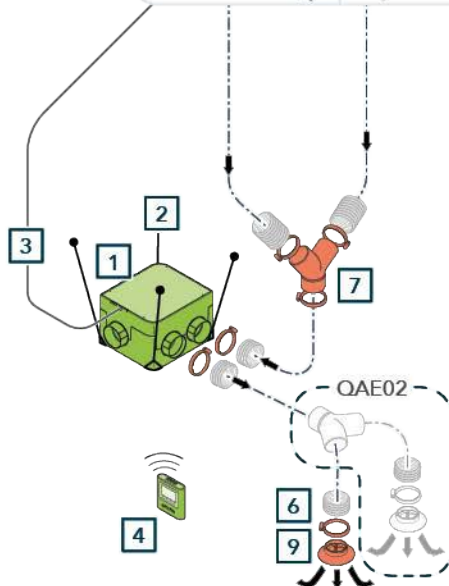
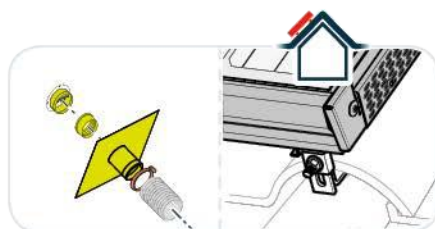

Code produit  
Product code  
Produktcode  
Productcode  
Codice prodotto  
Código do produto

**9**

Réglage usine **X**  
Factory settings  
Werkseinstellungen  
fabrieksinstellingen  
condizioni iniziali  
Regulamento fabrica

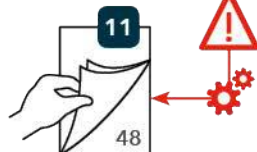

 MAVEIS05

 QAE09T

 QAE13

 OPTION



**i** — PAC-O / EXPLORER

**D**



Code produit  
Product code  
Produktcode  
Productcode  
Codice prodotto  
Código do produto







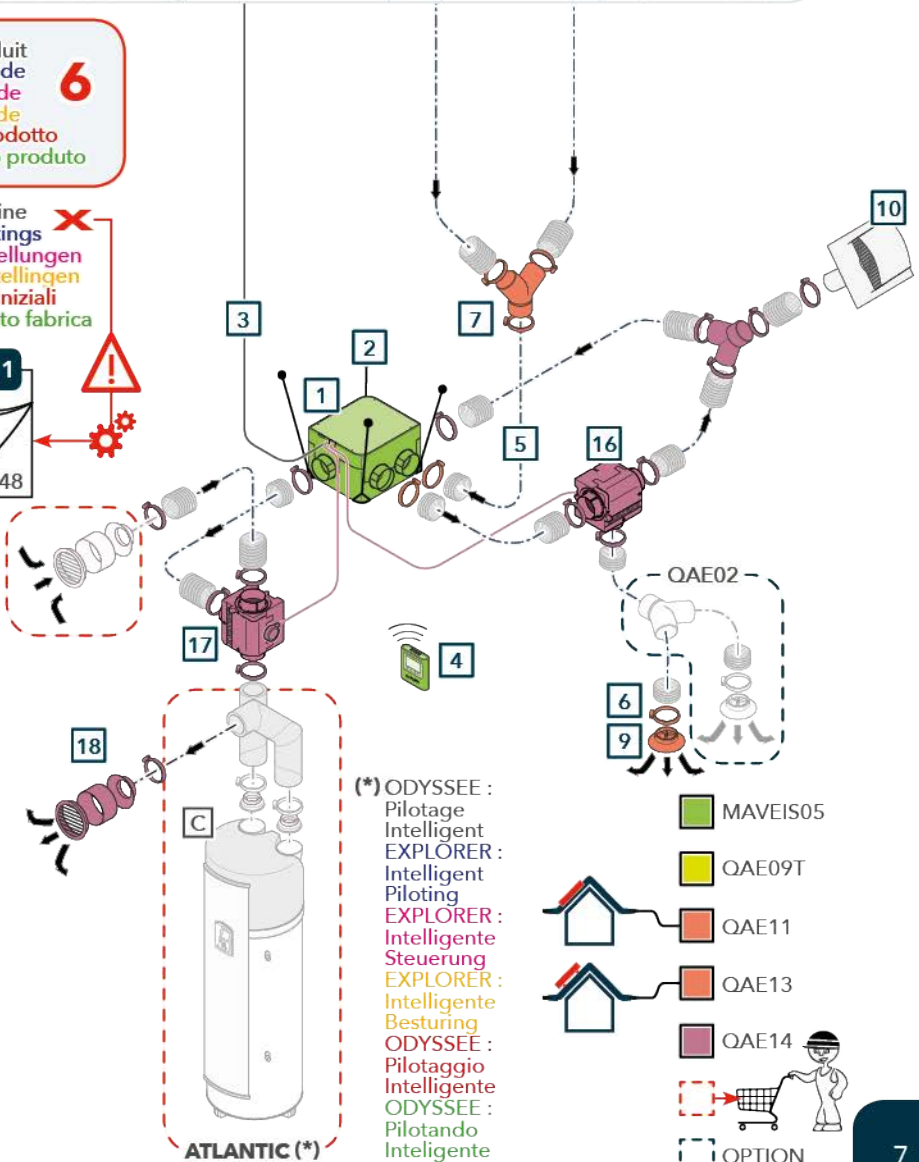
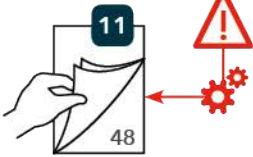

**6**

Réglage usine  
Factory settings  
Werkseinstellungen  
fabrieksinstellingen  
condizioni iniziali  
Regulamento fabrica

**X**



(\*) ODYSSEE :  
Pilotage  
Intelligent  
EXPLORER :  
Intelligent  
Piloting  
EXPLORER :  
Intelligente  
Steuerung  
EXPLORER :  
Intelligente  
Besturing  
ODYSSEE :  
Pilotaggio  
Intelligente  
ODYSSEE :  
Pilotando  
Inteligente

-  MAVEIS05
-  QAE09T
-  QAE11
-  QAE13
-  QAE14
-   OPTION
-  OPTION

i

Cordelette  
String  
Kordel  
Netsnoer  
Filo  
Cordão

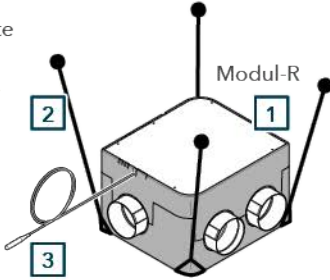

Capteur de température  
Temperature sensor  
Temperaturmessfühler  
Temperatuurs voeler  
Sonda temperatura  
Sonda temperatura

Thermostat d'ambiance  
Thermostat  
Temperaturbegrenzer  
Veiligheidsklixon  
Termostato  
Termostato



10 Chapeau de toiture  
Roof cap  
Dachhaube  
Dakkap  
Prese aria esteve  
Chapéu de ar

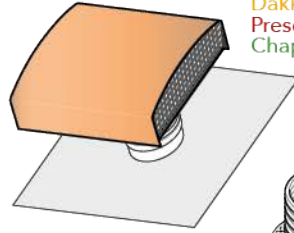

5 Gaine isolée  
Insulated duct  
Isolierte leitung  
Geïsoleerde  
ventilatieslang  
Condotta isolato  
Tubo isolado



6 Collier de serrage  
Hose clip  
Schlauchschelle  
Spanring  
Fascetta  
Abraçadeira



7 Raccord "Y"  
"Y" pipe  
"Y" Rohr  
"Y" leiding  
Tubo "Y"  
Tubo "Y"

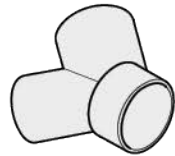

8 Piquage amovible  
Removable air taping  
Lösbare Verbindung  
Oplosbare verbinding  
Raccordo solubile  
Ligador solvável



9 Bouche d'aération  
Air vent  
Luftaustritt  
Luchtrooster  
Canale di scarico  
Conduta de ventilação

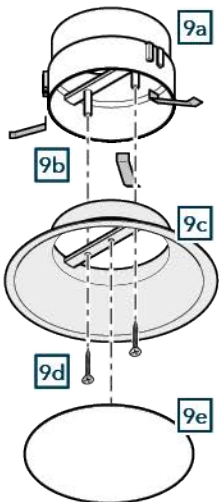



- 13** Piquage amovible  
Removable air tapping  
Lösbare Verbindung  
Oplosbare verbinding  
Raccordo solubile  
Ligador solvável



- 14** Clapet anti retour  
Non return flap  
Rückschlagventil  
Terugslagklep  
Clapet antiritorno  
Válvula anti rétorno



- 15** Manchon de raccordement  
Rubber connecting sleeve  
Verbundmanschette  
Verbindingshuls  
Manicotto di giunzione  
Gola

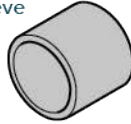

- 12** Capteur de température  
Temperature sensor  
Temperaturmessfühler  
Temperatuurs voeler  
Sonda temperatura  
Sonda temperatura

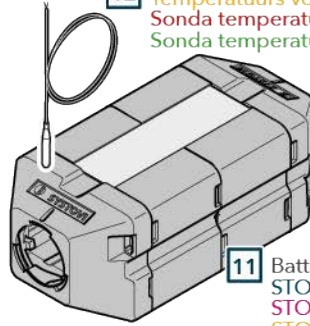

- 11** Batterie STOCK-R  
STOCK-R battery  
STOCK-R Batterie  
STOCK-R batterij  
Batteria STOCK-R  
Bateria STOCK-R

- 16** Vanne 3 voies motorisée  
Motorized 3 way valve  
Motorisiert 3 Weg Ventil  
Gemotoriseerde 3 wegskraan  
Motorizzato valvola 3 vie  
Motorizado válvula de 3 vias

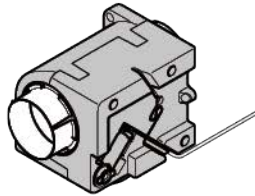

- 17** Connecteur ODYSSEE  
ODYSSEE connector  
ODYSSEE Steckverbinder  
ODYSSEE connector  
Raccorderia ODYSSEE  
Ligações ODYSSEE

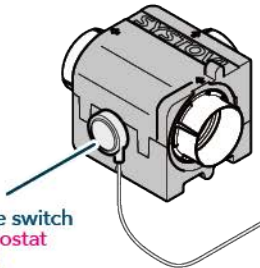

- Pressostat  
Air pressure switch  
Druckpressostat  
Pressostaat  
Pressostato  
Pressostato

- 18** Bouche d'aération  
Air vent  
Luftaustritt  
Luchtrooster  
Canale di scarico  
Condução de ventilação

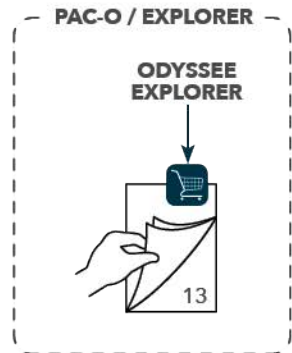
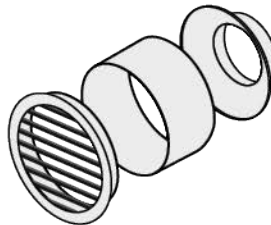



- FR - L'installation et la première mise en fonctionnement de l'appareil doivent être effectuées par un professionnel qualifié uniquement. Ce dernier est responsable de la conformité de l'installation et de la mise en fonctionnement selon la réglementation en vigueur.
- EN - The installation and commissioning of the unit must be performed only by a qualified professional. The latter is responsible for the compliance of the installation in accordance with the relevant regulations.
- DE - Das Gerät darf nur von einem qualifizierten Techniker installiert werden. Welches ist auch verantwortlich für die fachgerechte Installation und Inbetriebnahme
- NL - Het toestel mag enkel door een erkende technicus geïnstalleerd worden. Die is ook verantwoordelijk voor de deskundige installatie en in gebruikneming.
- IT - L'installazione dell'apparecchio deve essere eseguita esclusivamente da un tecnico abilitato a norma di legge. Questi si assume anche la responsabilità per l'installazione, la regolazione e la messa in servizio conformi alle norme.
- PT - Estes dispositivos devem ser instalados somente por um instalador autorizado responsável pelo cumprimento de todas as instruções, normas e orientações.

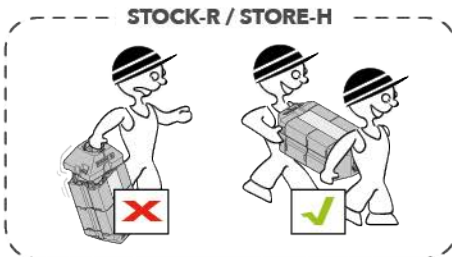
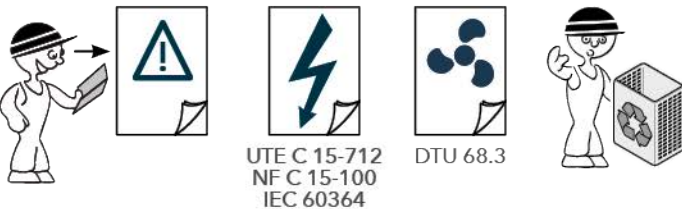



← mm →

**1** **2** ...

**1** **2** **3** **4** ...

**1** **2** **3** **4** ...

millimètre  
millimeter  
Millimeter  
millimeter  
millimetro  
milímetro

étapes  
steps  
Schritte  
stappen  
tappe  
fases

sous-étapes  
sub-steps  
Unterchritte  
substappen  
sotto tappe  
debaixo de fases

ordre de montage  
mounting order  
steigende Ordnung  
bevestiging bestelling  
ordine che monta  
ordem montando



Aérothermique  
Aerothermal  
Aerothermische  
Aerothermische  
Aeroteramico  
Aerotérmico

Réglage  
Adjustment  
Anpassung  
Aanpassing  
Regolazione  
Regulação

Test  
Test  
Test  
Test  
Test  
Teste

Info client  
Customer info.  
Kunden Info  
Klant info  
Info clienti  
Info clientes

Maintenance  
Servicing  
Wartung  
Onderhoud  
Manutenzione  
Manutenzione



Intégré / In Roof

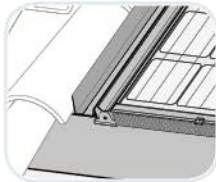

Sur-toiture / On Top





i

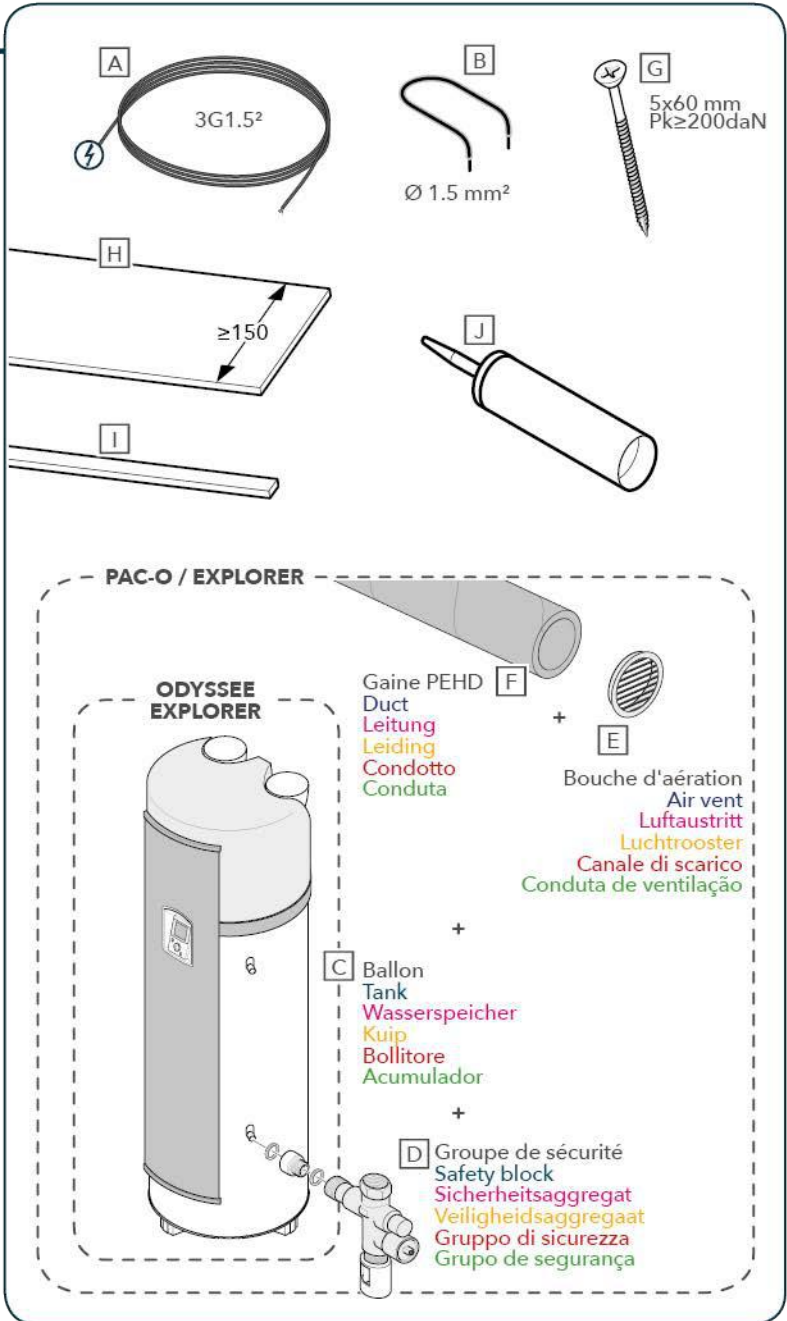



1

**Modul-R  
Modul-AIR  
MAVEIS05**

**230VAC**  
**1,5A**  
**250W**

**IP21**

**11 KG**

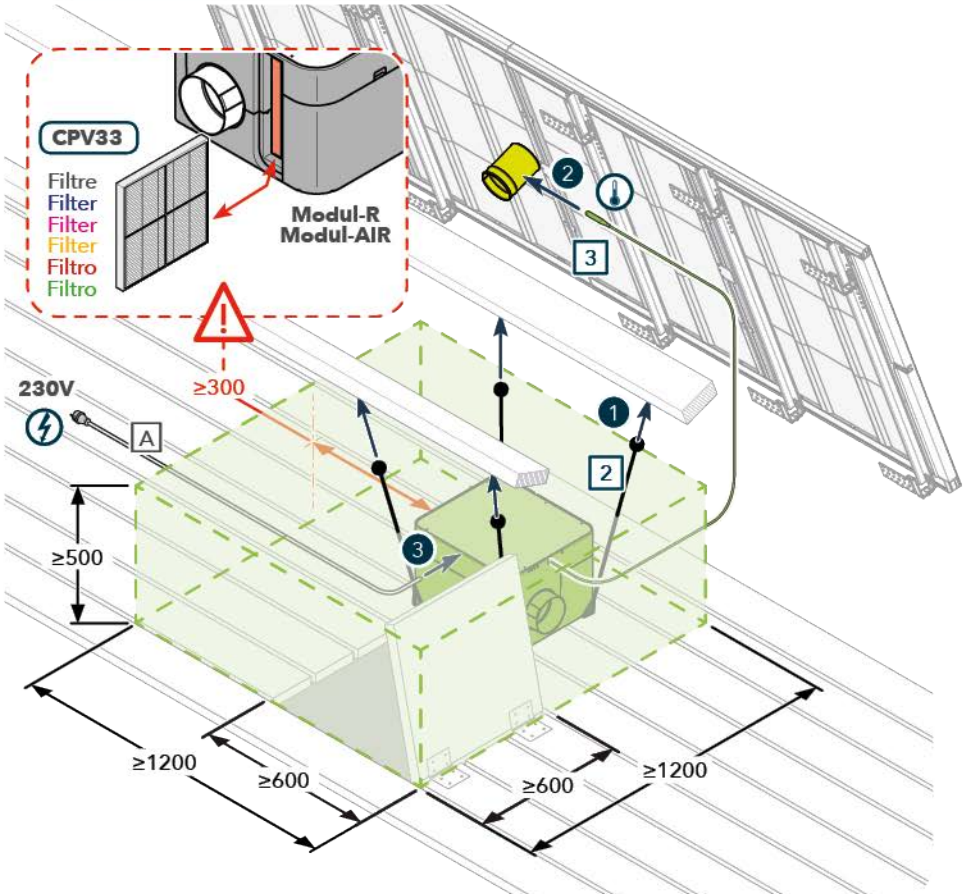
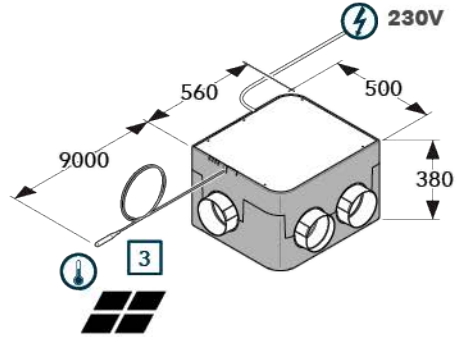

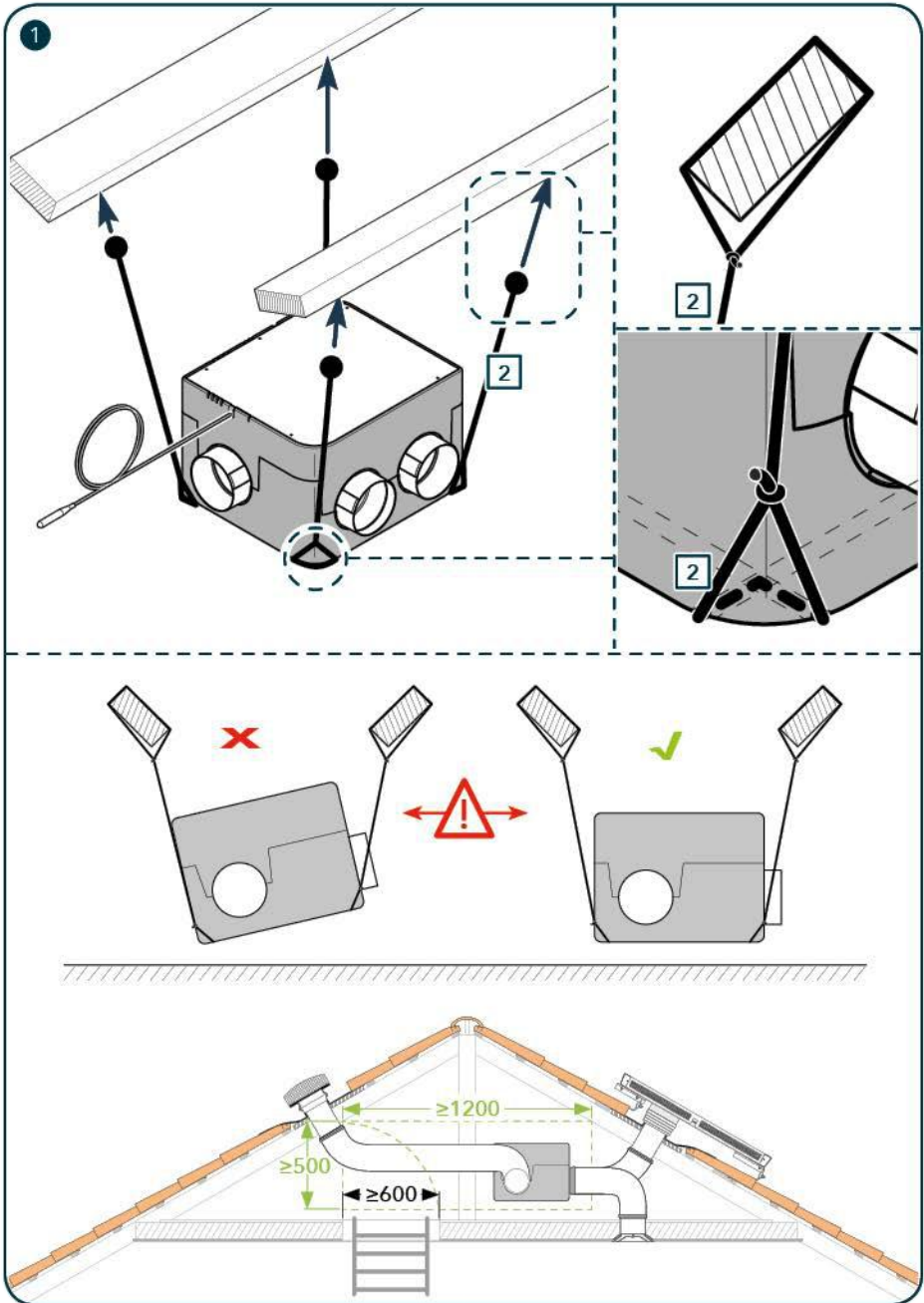

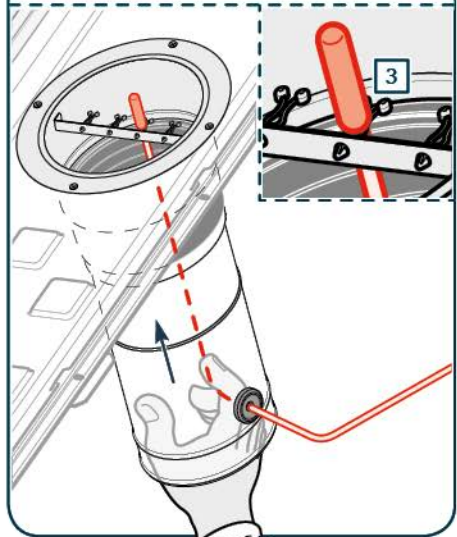
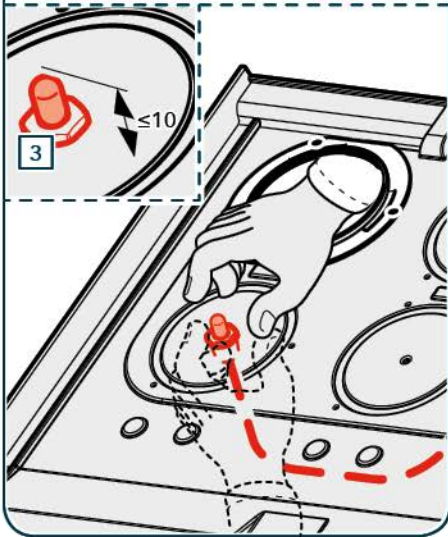
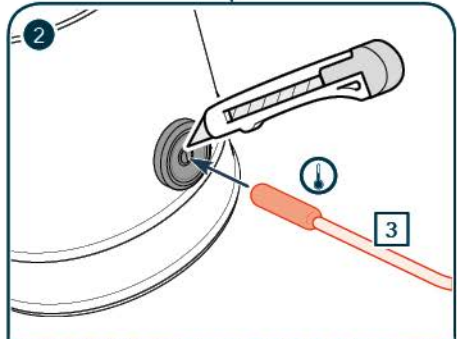
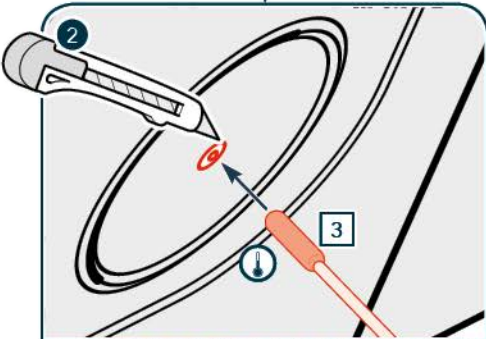
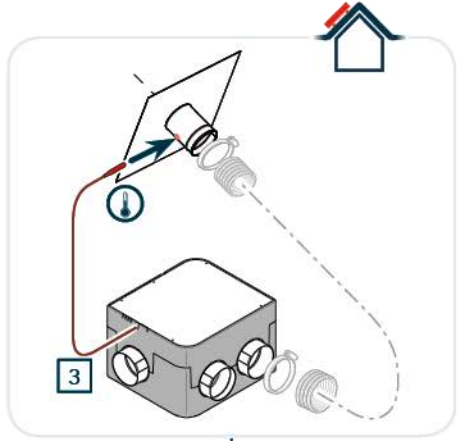
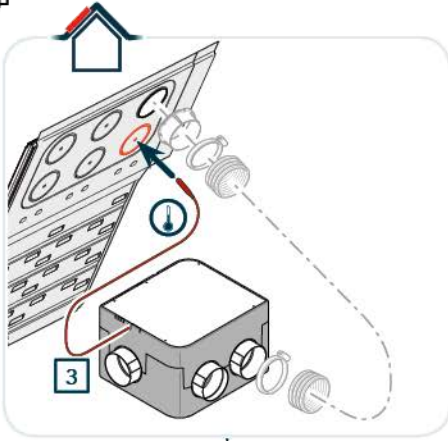



3

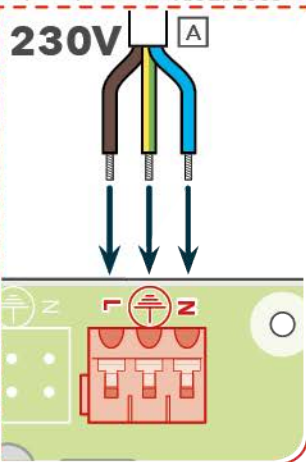
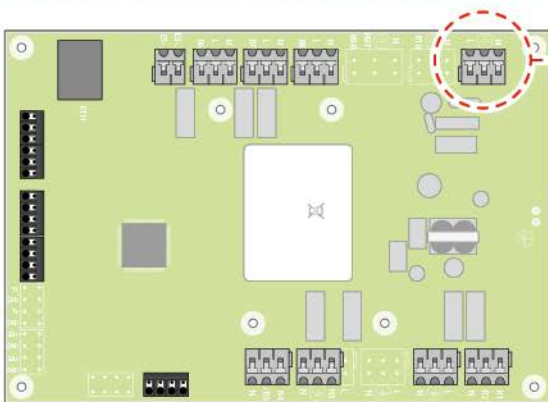
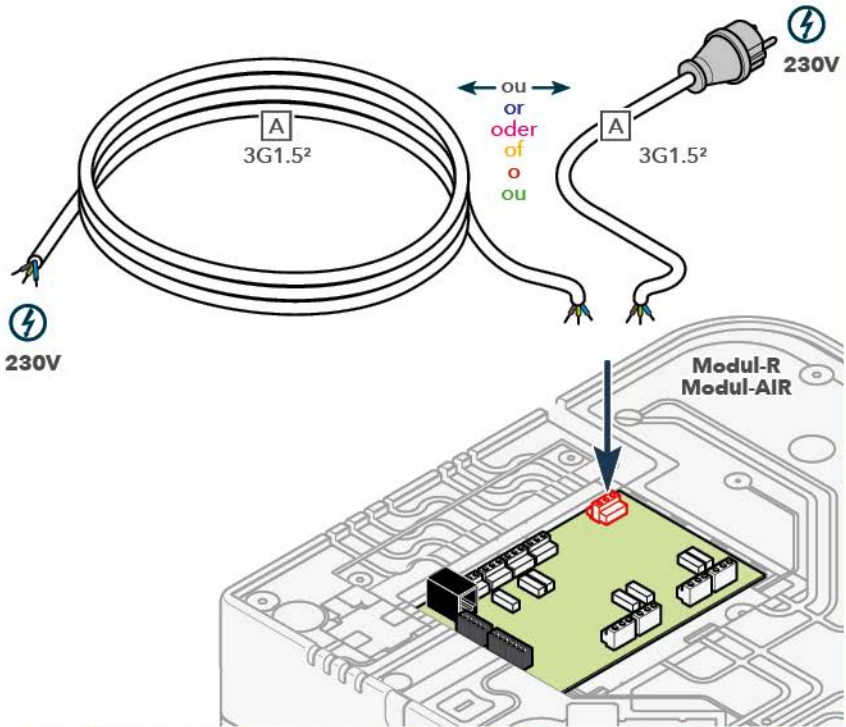

 STOCK-R / STORE-H

2

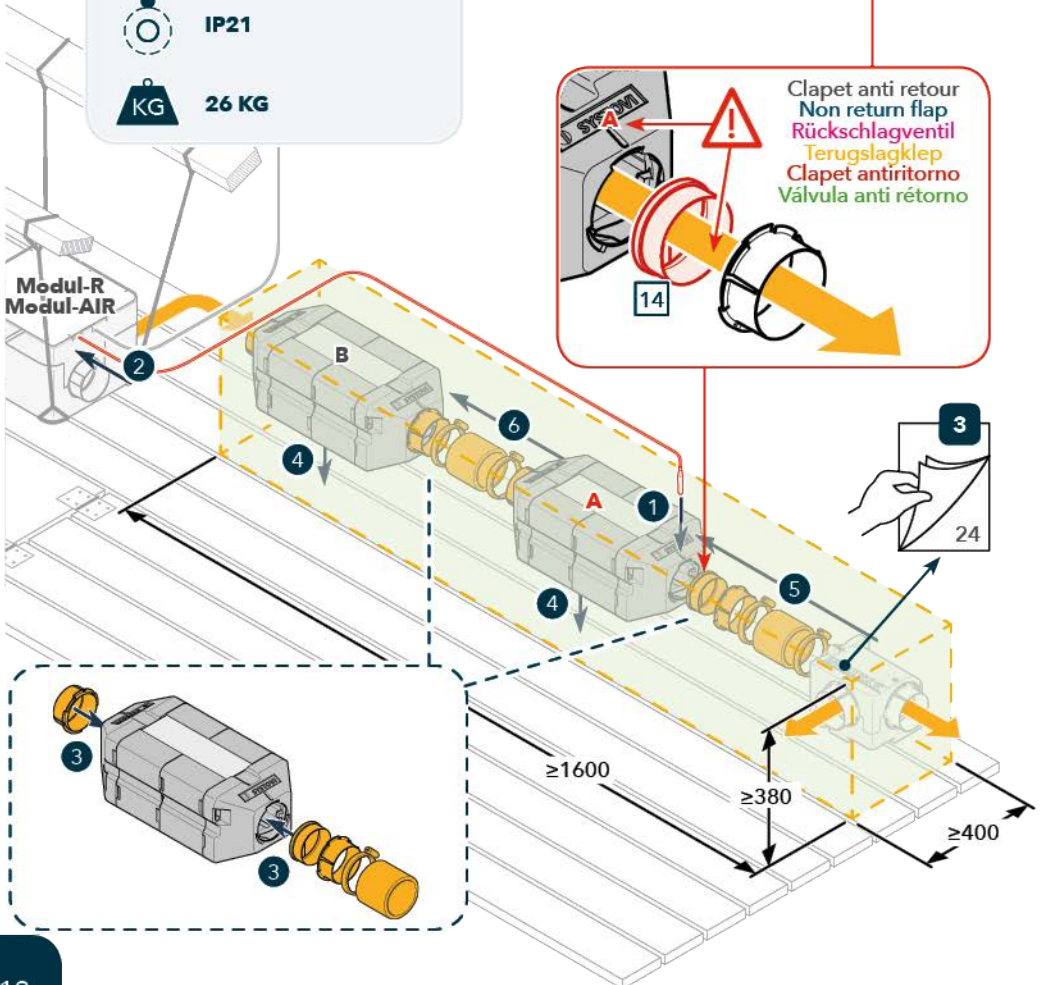
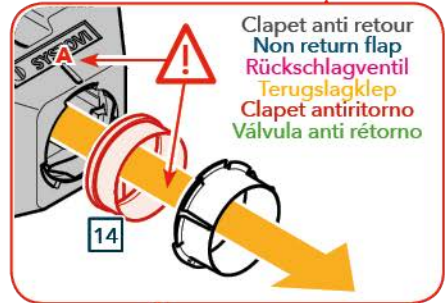
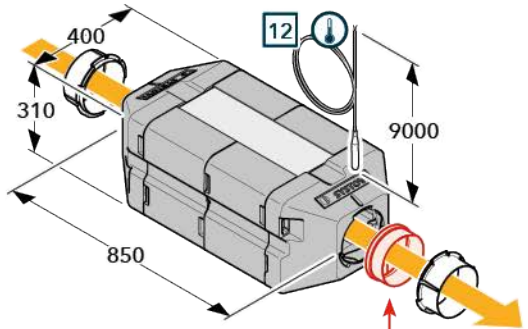
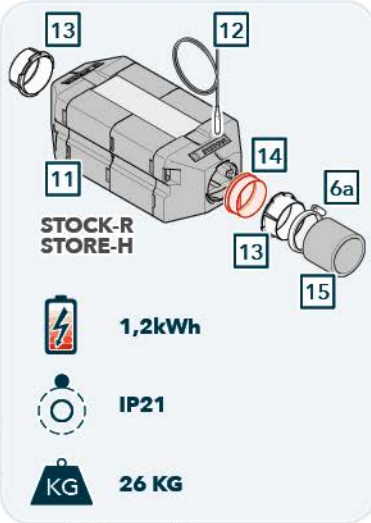

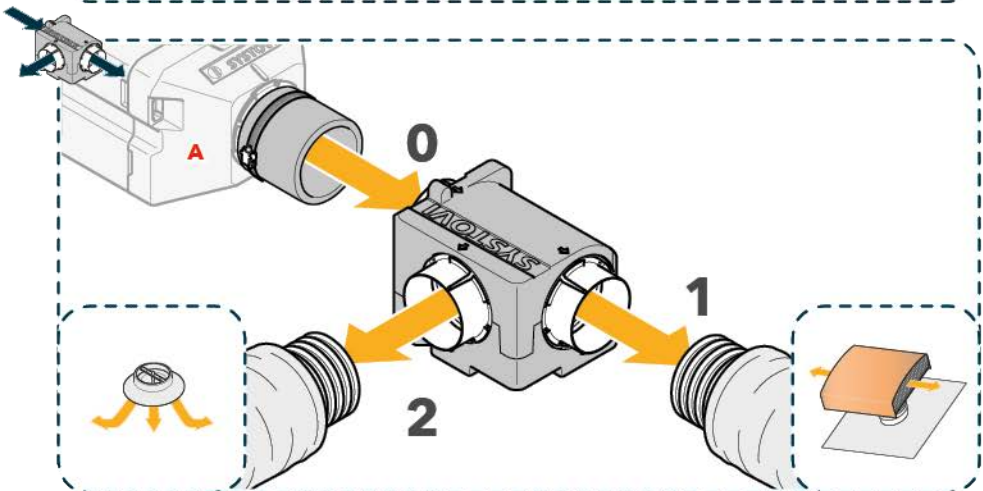
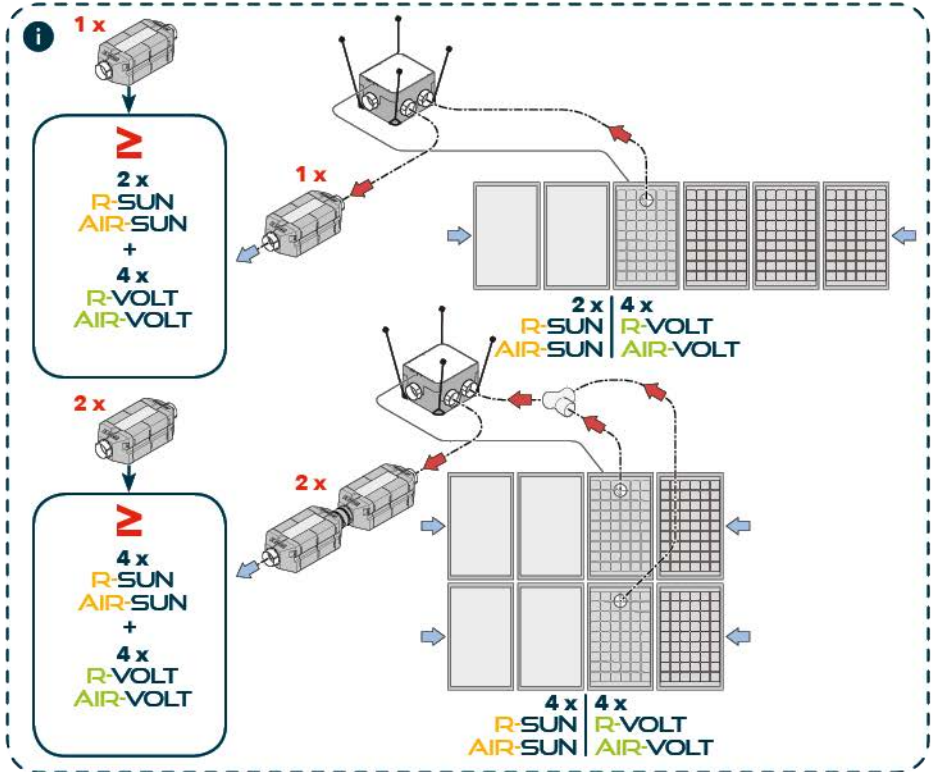

STOCK-R / STORE-H

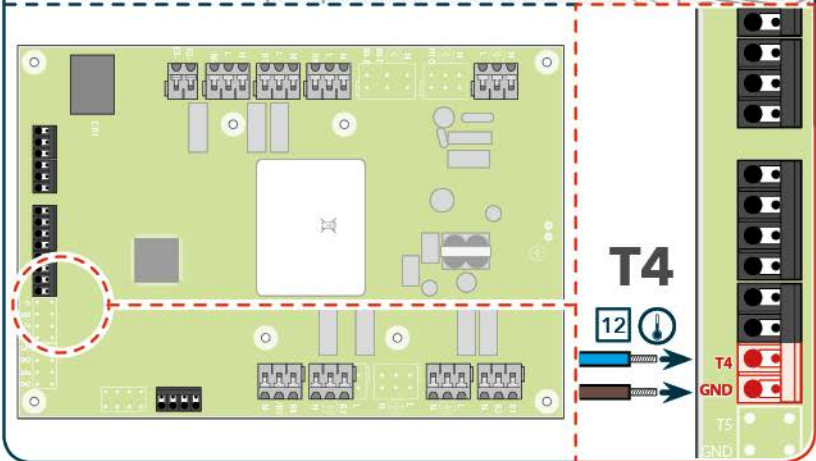
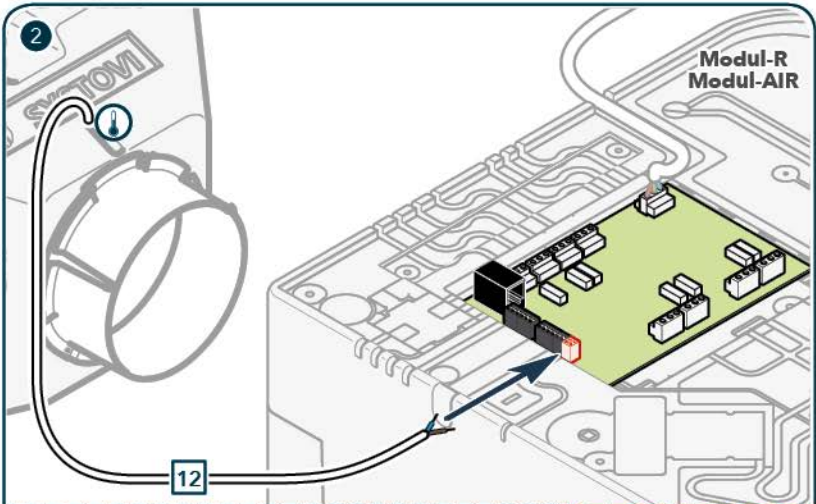
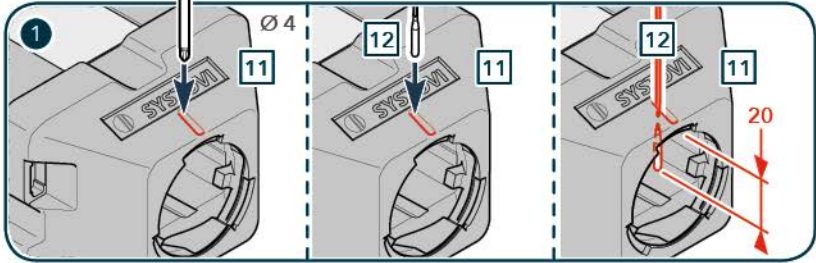

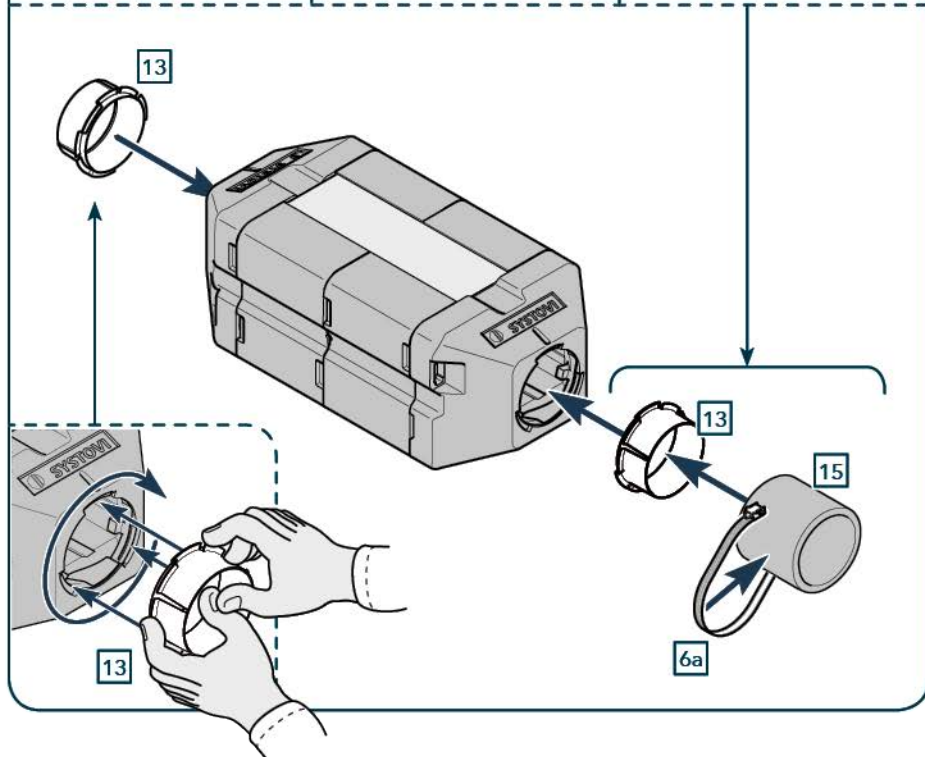
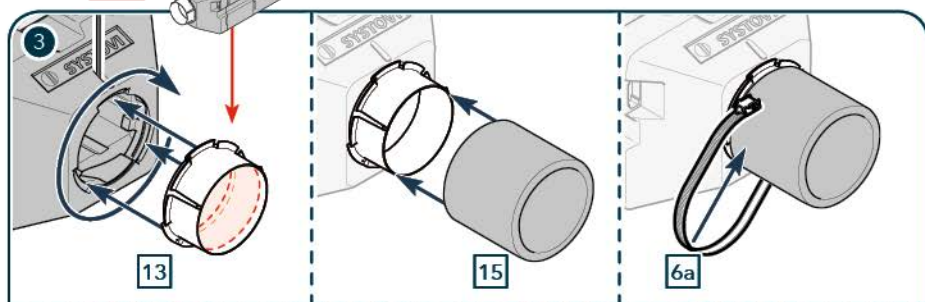

 STOCK-R / STORE-H

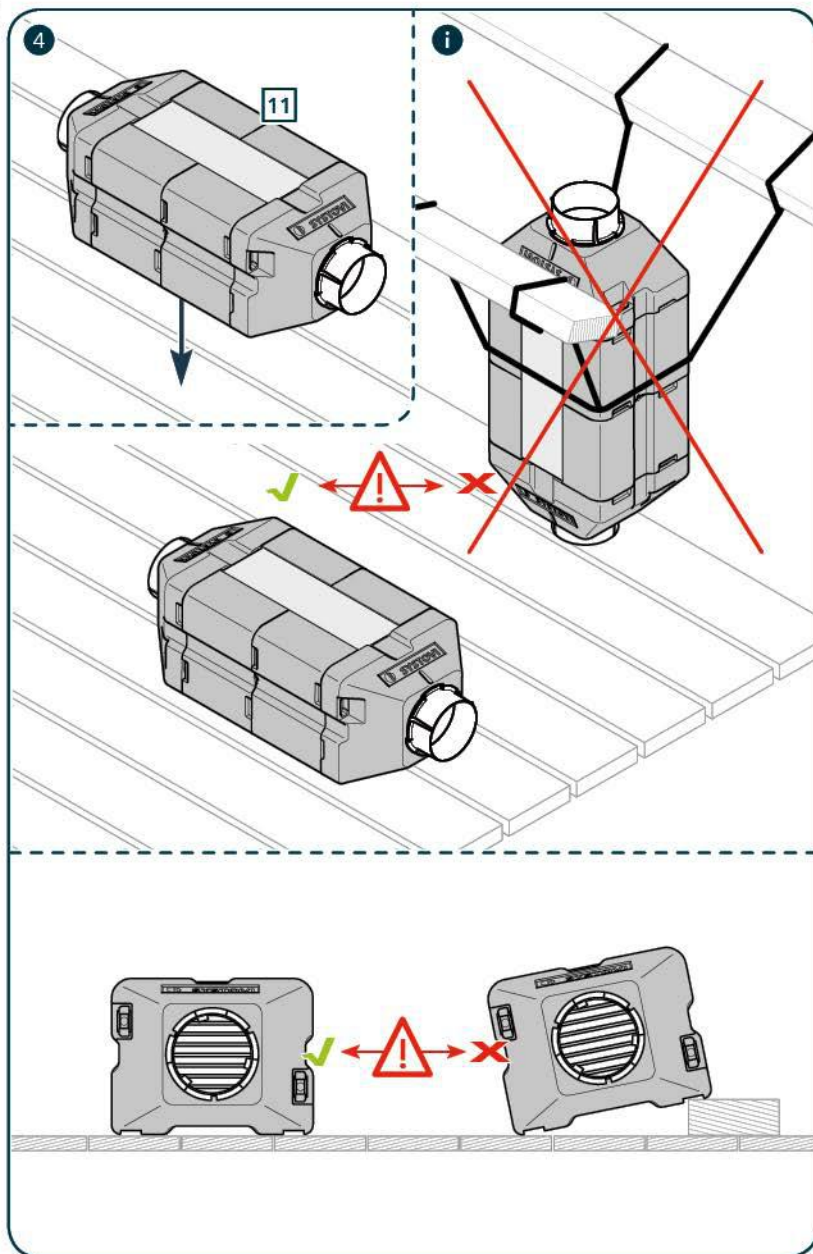

 STOCK-R / STORE-H

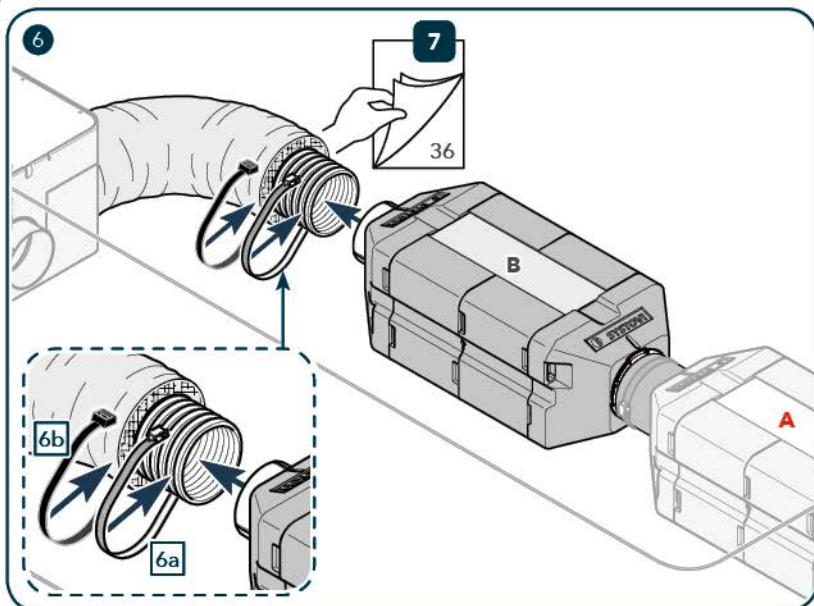
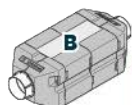
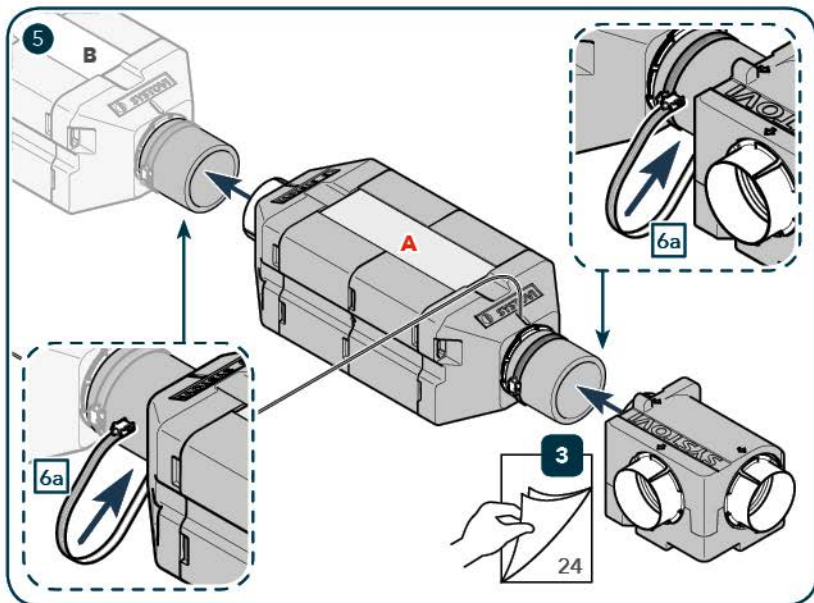



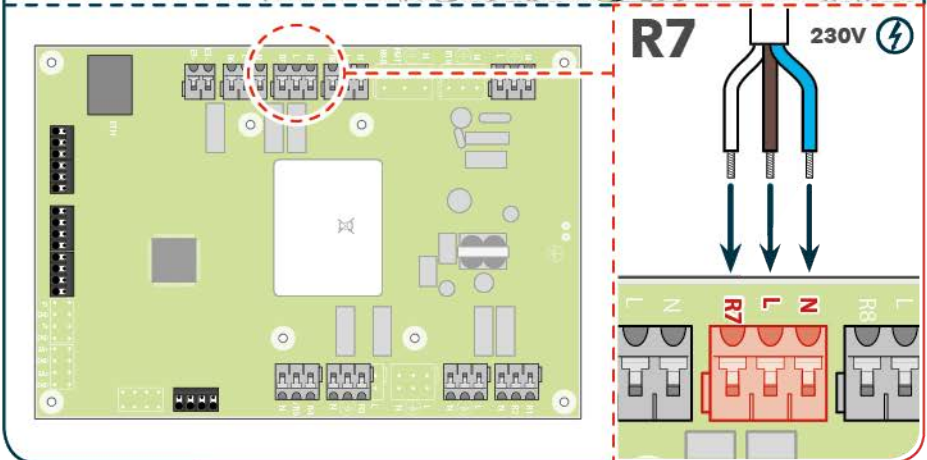
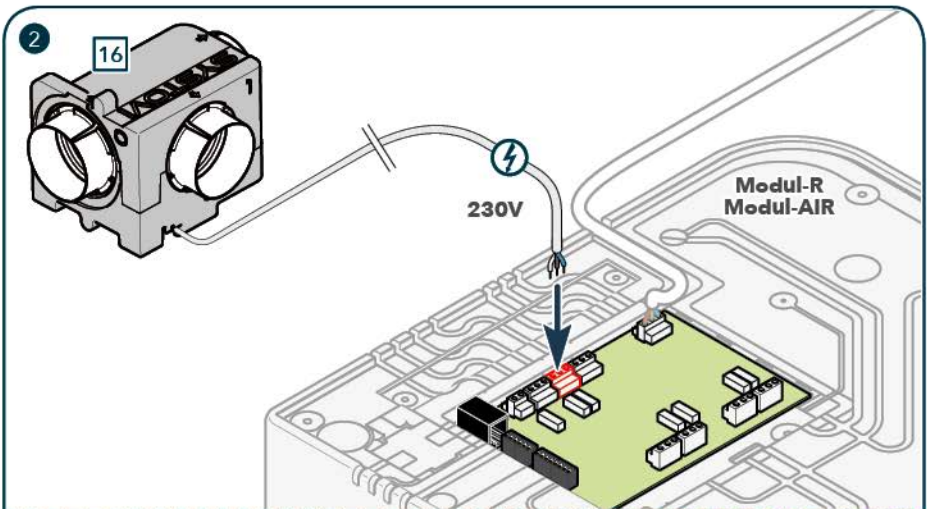
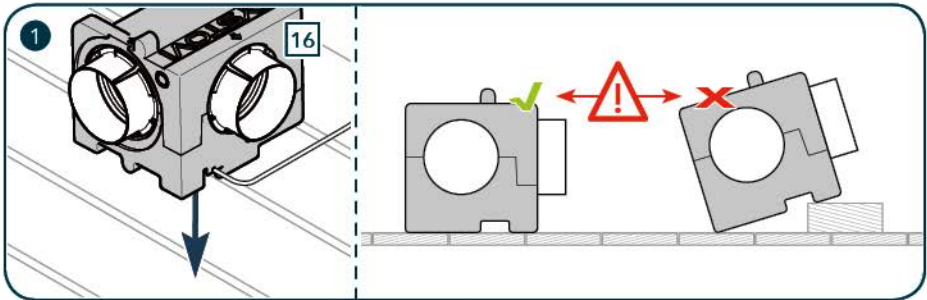

 PAC-O / EXPLORER

4

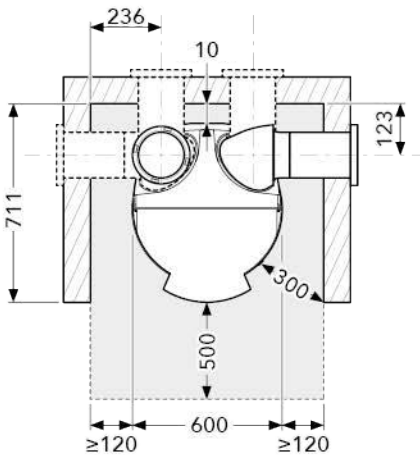
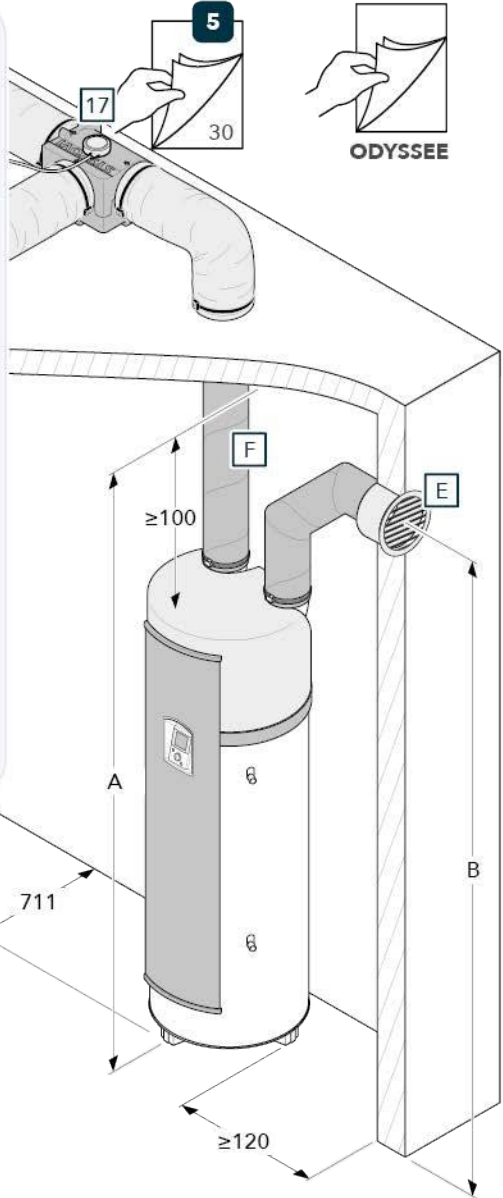
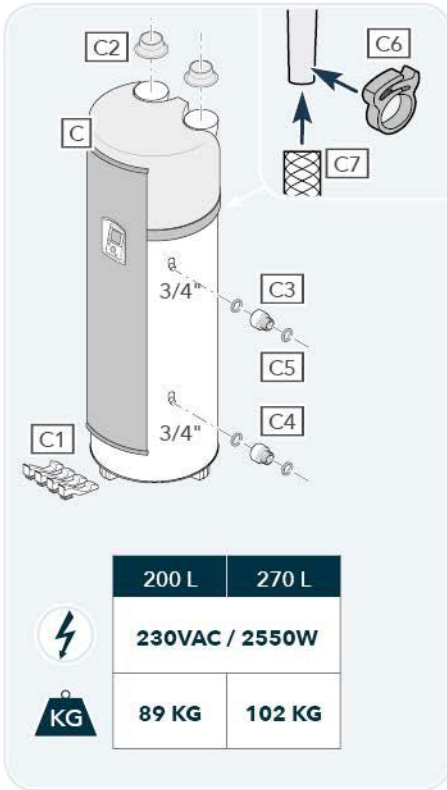

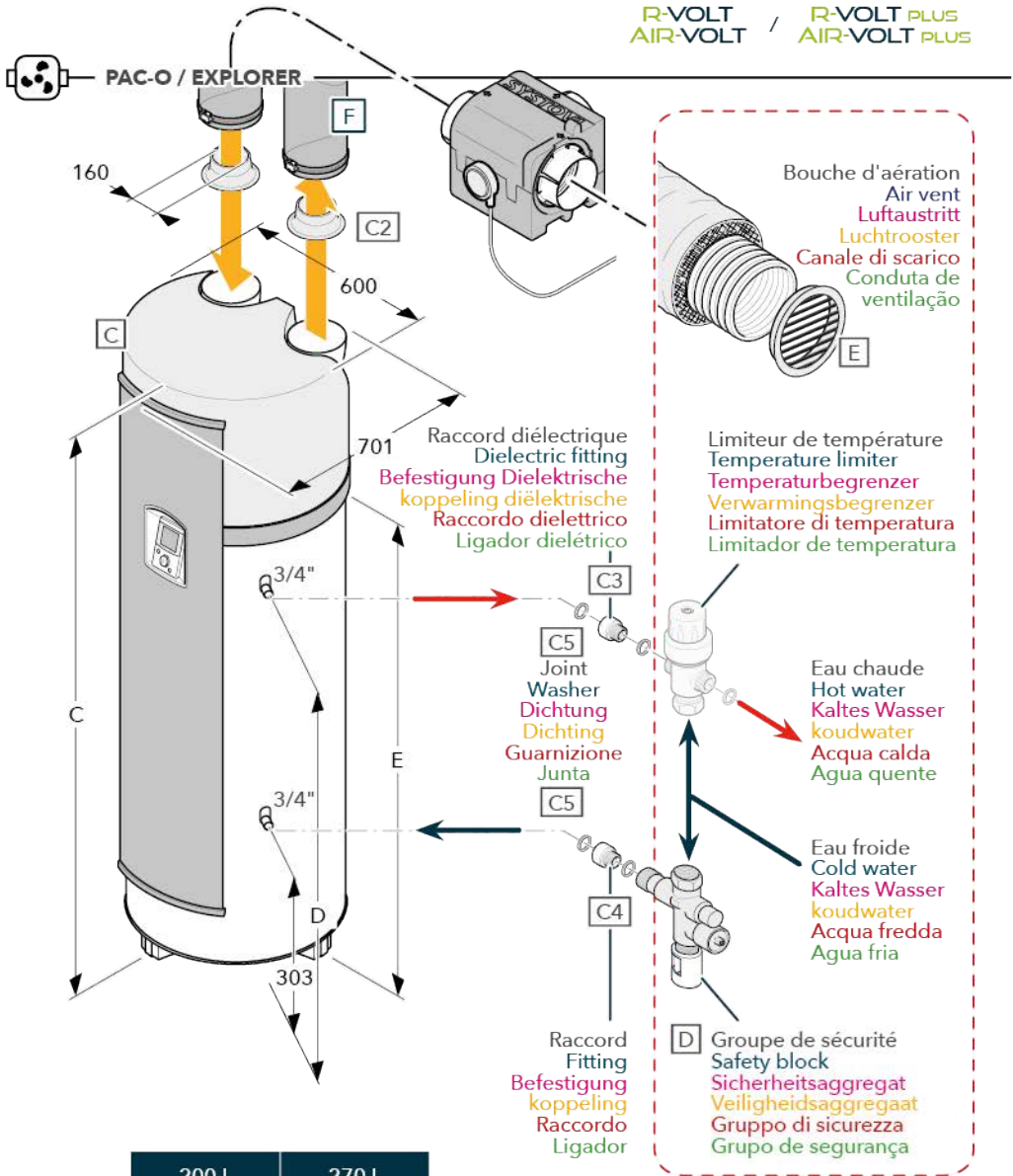

	200 L	270 L
A	≥ 1820	≥ 2160
B	≥ 1584	≥ 1928
C	1714	2060
D	957	1303
E	1202	1534



PAC-O / EXPLORER

ODYSSEE / EXPLORER

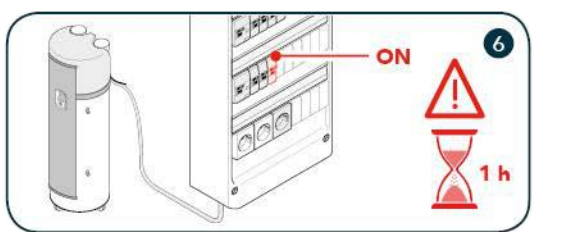
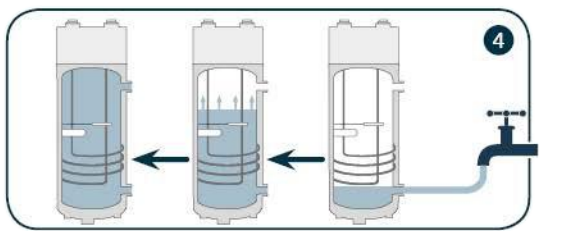
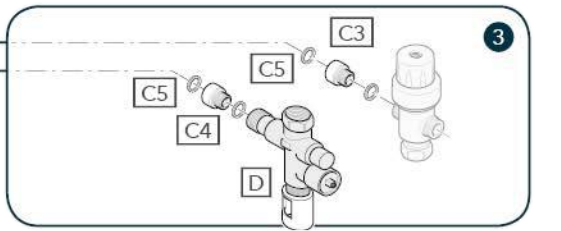
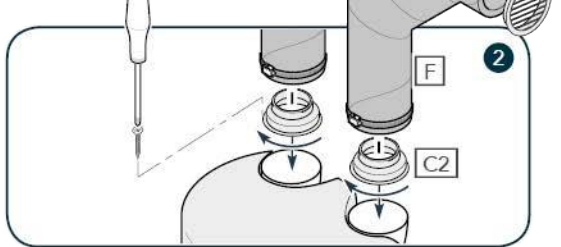
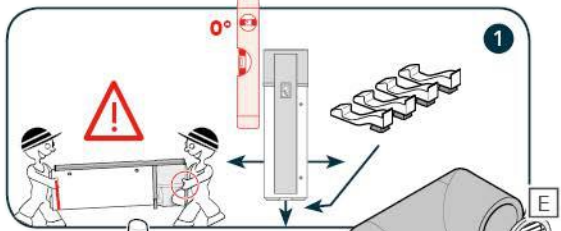
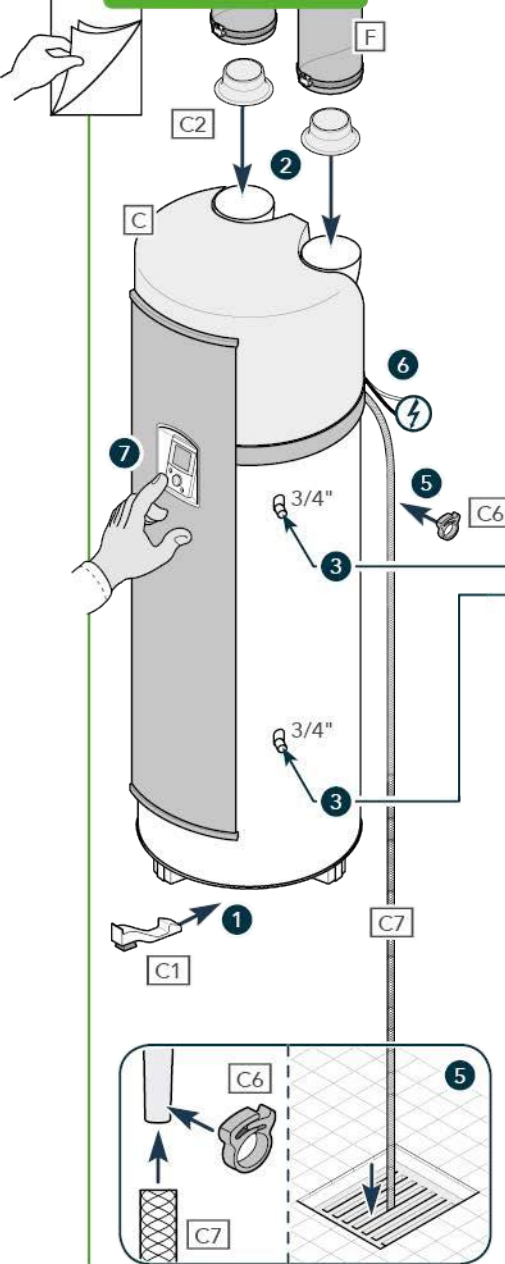

**7** PREMIÈRE MISE EN SERVICE - FIRST ENTRY INTO SERVICE  
ERSTEN INBETRIEBNAHME - EERSTE INGEBRUIKNEMING  
PRIMA MESSA IN SERVIZIO - PRIMEIRA ENTRADA EM SERVIÇO

**PARAMÈTRES  
SETTINGS  
EINSTELLUNGEN  
INSTELLINGEN  
PARAMETRI  
PARÂMETROS**

**7a** → Plages de fonctionnement - 9h - 18h →  
Operating ranges  
Strände von Funktionieren  
Bedrijfsbereik  
Campo di lavoro  
Gamas de funcionamento

MENU	
BOOST	
Mode	AUTO
Absence	
Information	
Paramétrages	

Paramétrages	
Plages de fonctionnement	
Plage 1	09:00 à 18:00
Plage 1	--:-- à --:--
Durée totale: 10h	
Continuer	



**7b** → Gainage Casing  
Mantel  
Kanalasatie  
Smeer  
Bainha

Extérieur / Extérieur  
Exterior / Exterior  
Außeres / Außeres  
Buiten / buiten  
Esterno / Esterno  
Fora de / Fora de



**VÉRIFICATION DU FONCTIONNEMENT  
CHECKING THE FUNCTION  
FUNKTIONSPRÜFUNG  
CONTROLE VAN DE WERKING  
VERIFICA DEL FUNZIONAMENTO  
VERIFICAÇÃO DO FUNCIONAMENTO**

**7c** →

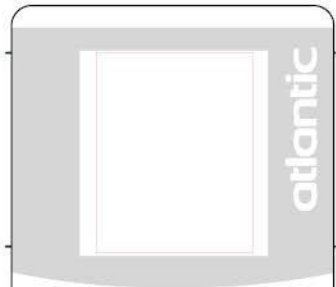

**MODE  
MODE  
MODUS  
MODUS  
MODO  
MODO**

**7d** →

~~MANUEL~~

MENU	
BOOST	
Mode	AUTO
Absence	
Information	
Paramétrages	

**MODE  
AUTO**

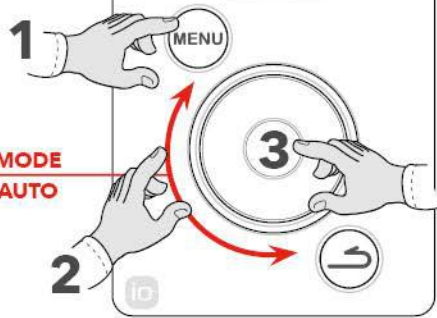
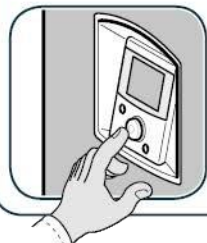

 PAC-O / EXPLORER

5

**17** Connecteur ODYSSEE  
 ODYSSEE connector  
 ODYSSEE Stecker  
 ODYSSEE connector  
 Raccorderia ODYSSEE  
 Ligações ODYSSEE

Pressostat  
 Air pressure switch  
 Druckpressostat  
 Pressostaat  
 Pressostato  
 Pressostato

**KG 1,4 KG**

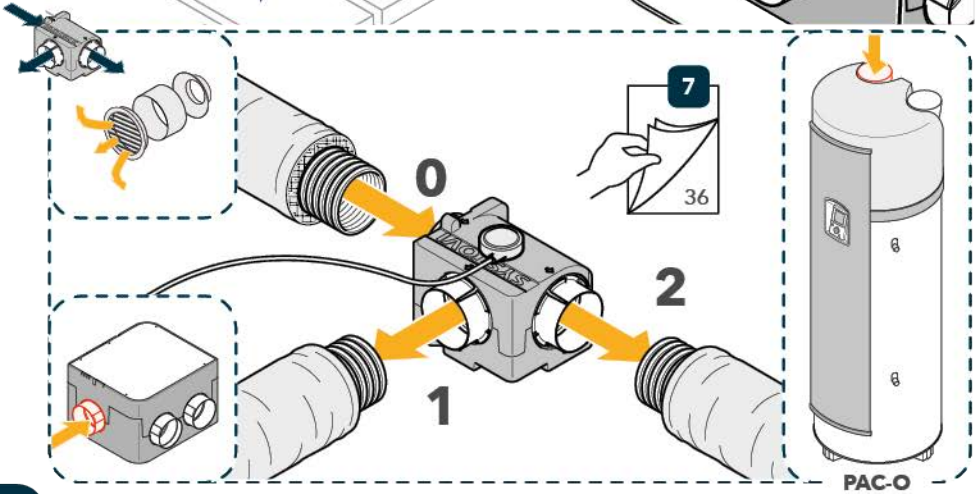
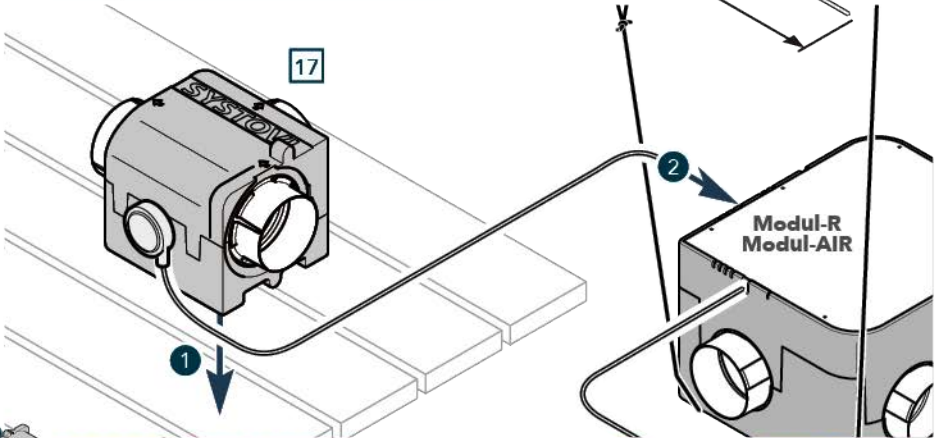
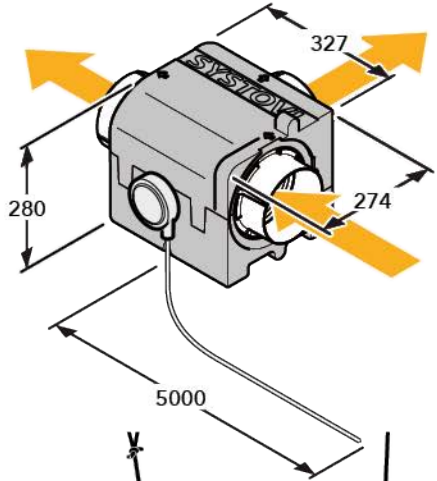

 PAC-O / EXPLORER

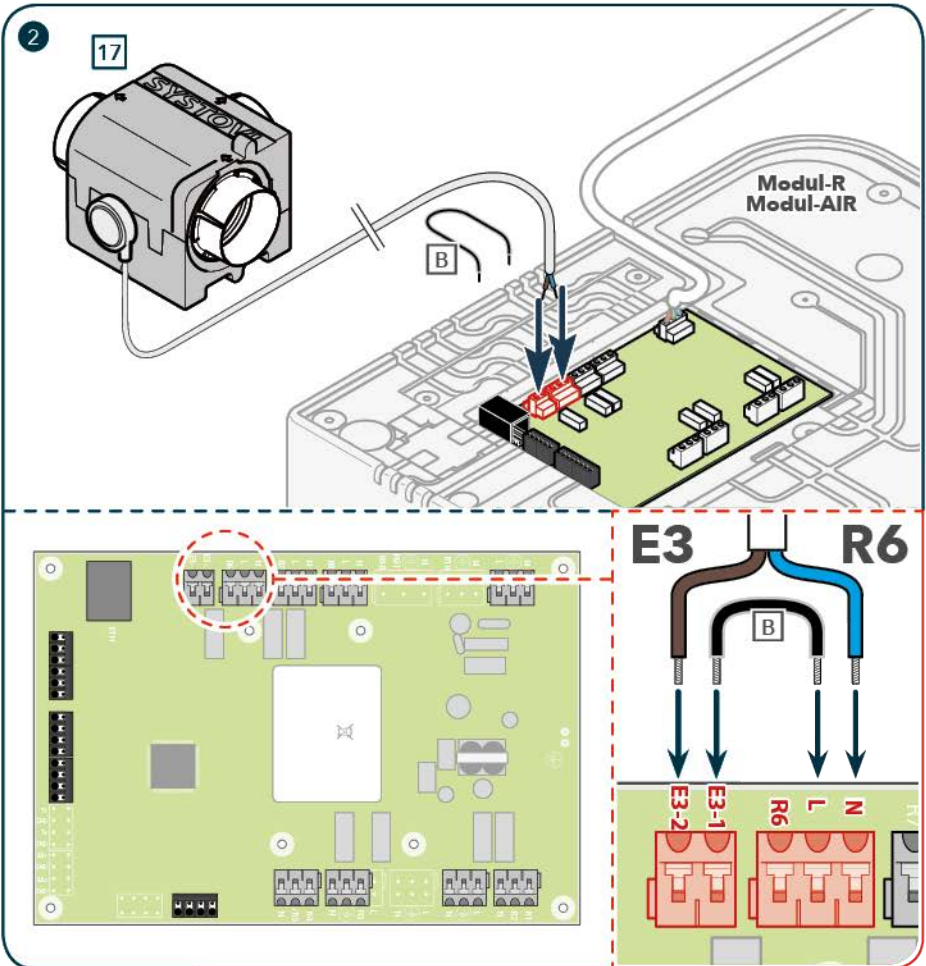
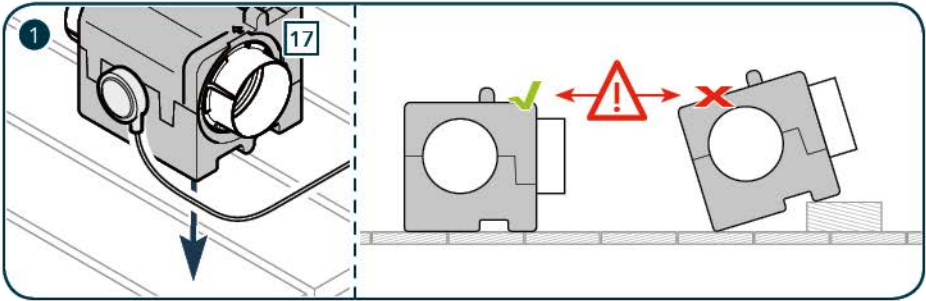



6

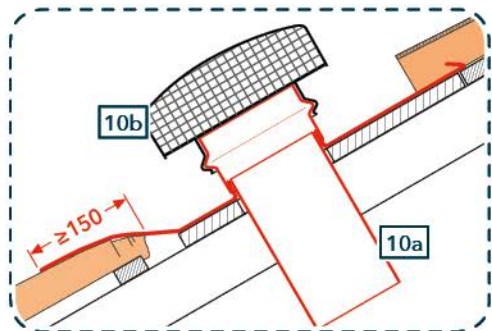
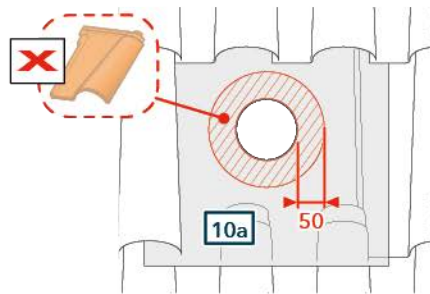
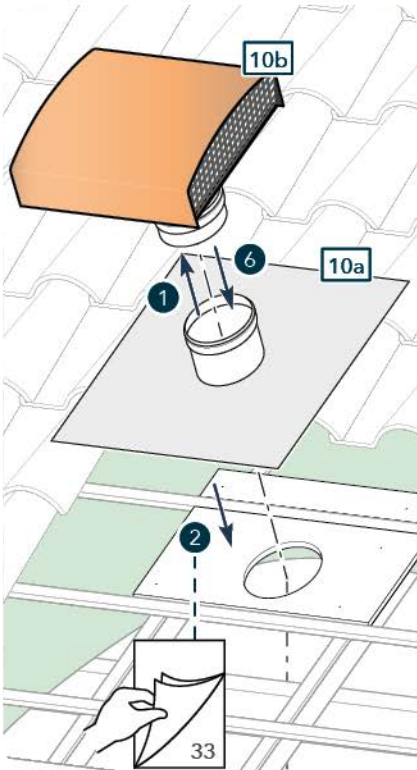
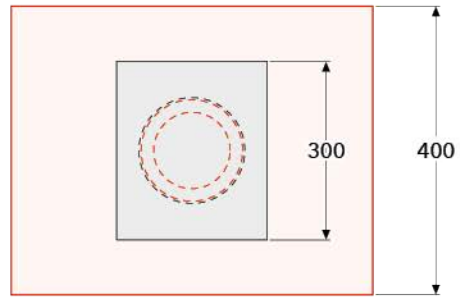
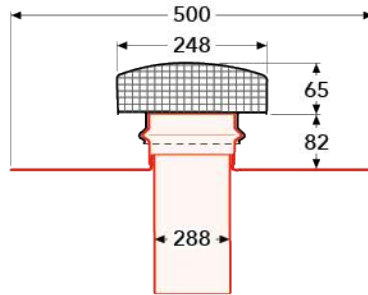
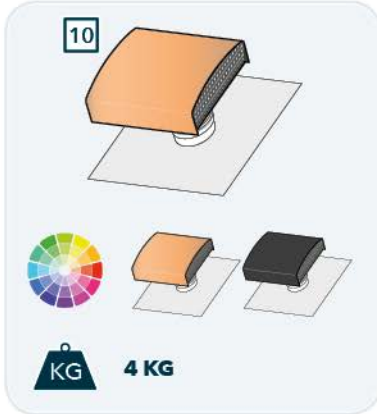

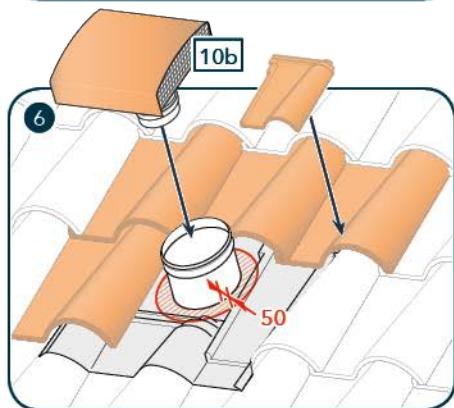
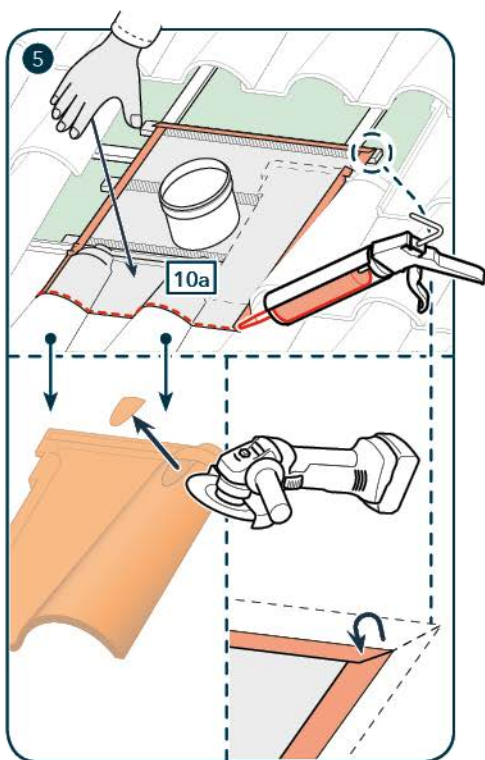
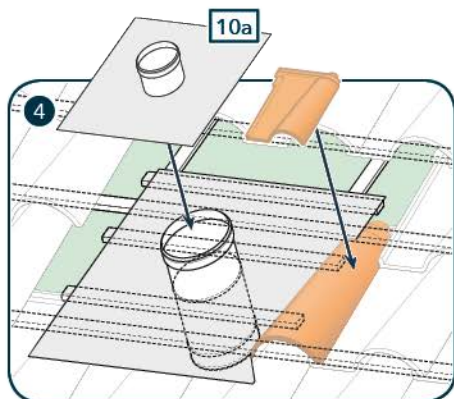
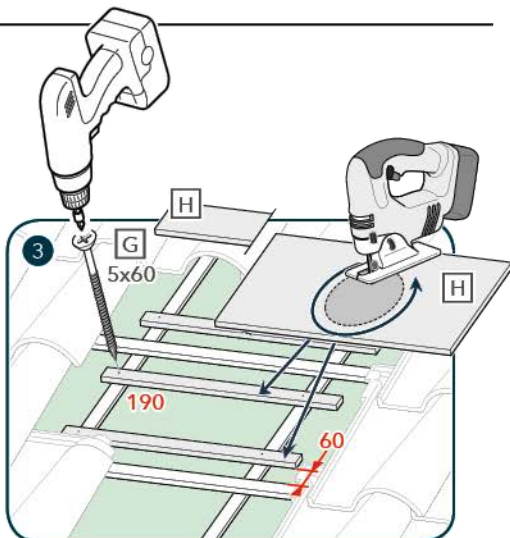
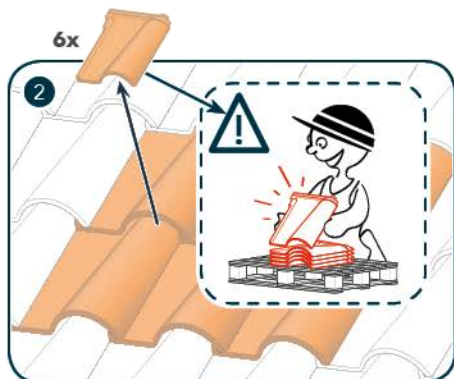



6

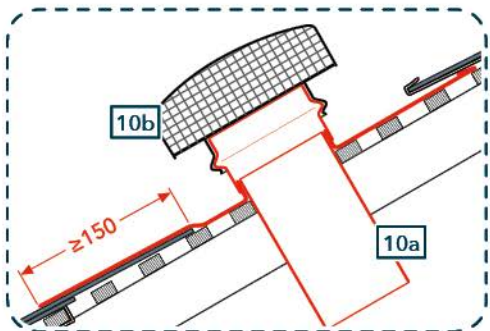
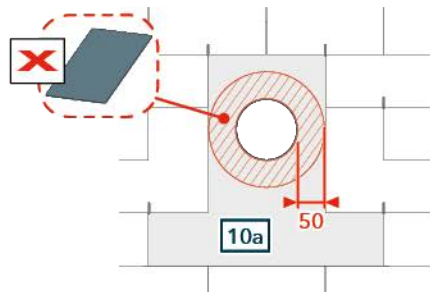
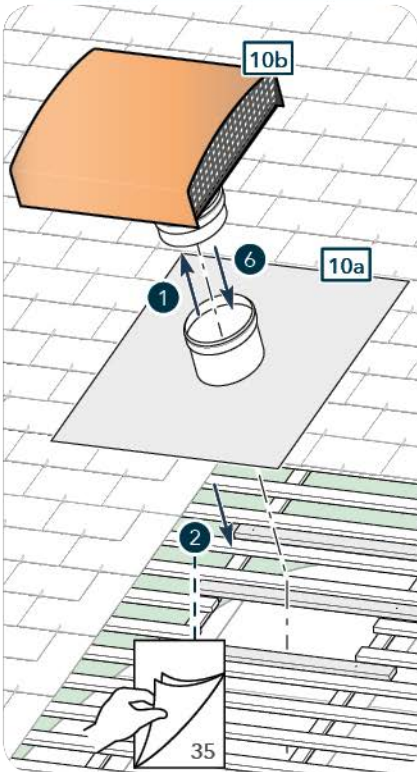
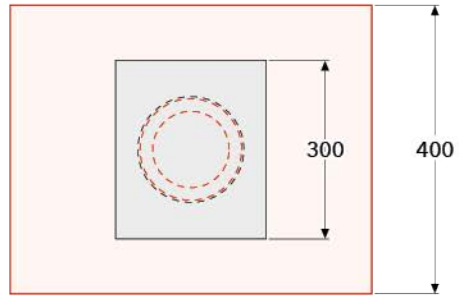
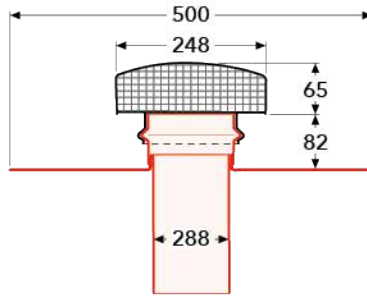
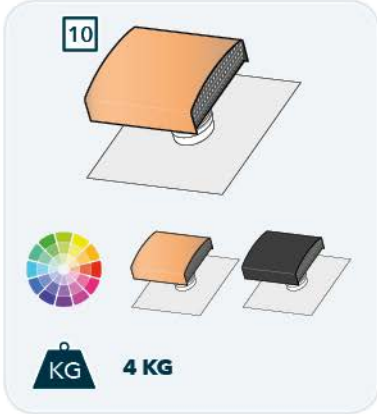

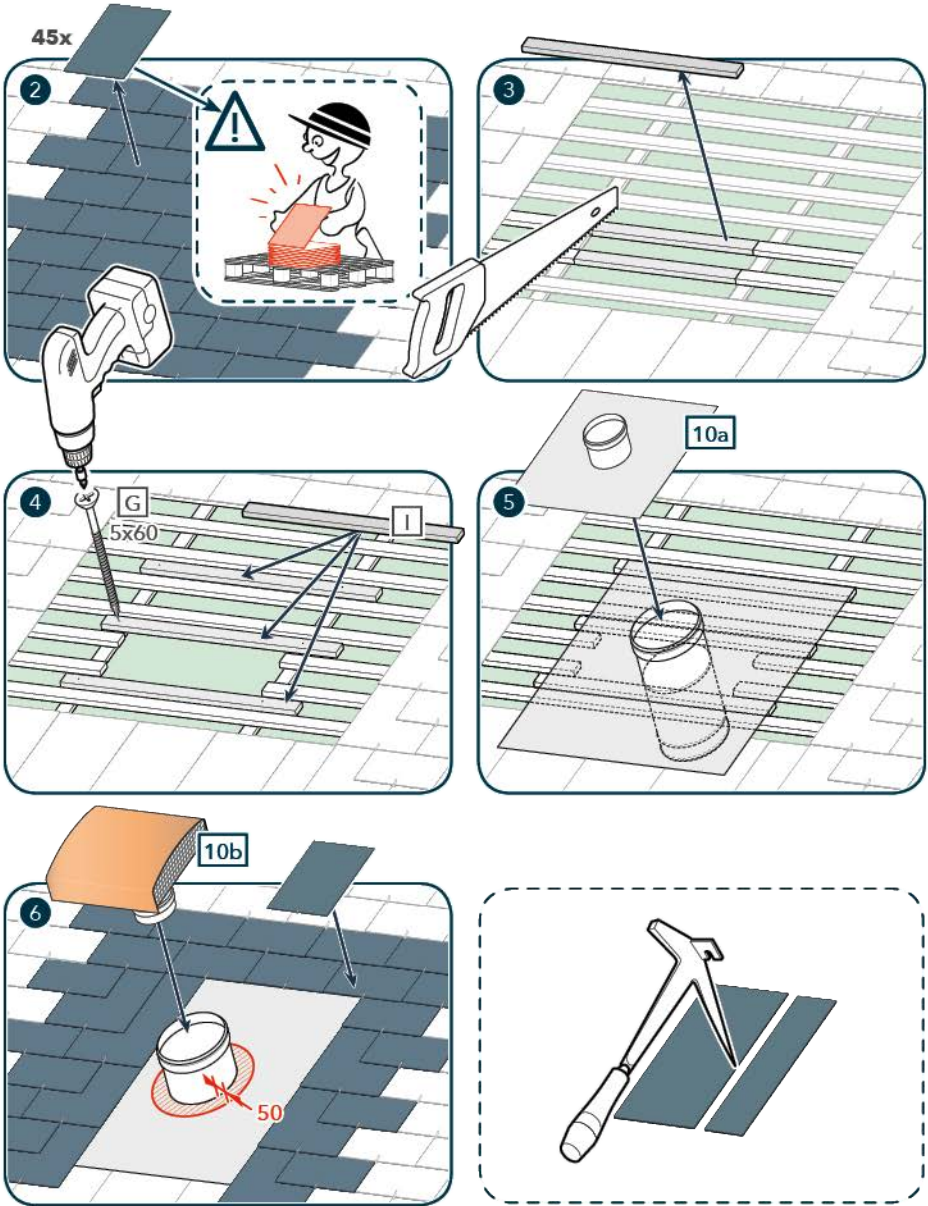



7

5

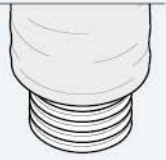

-30°C / +140°C



M1



3 KG

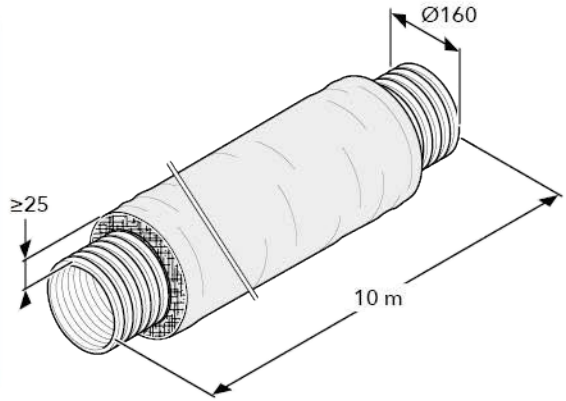

6

6b



Nylon



6b

6a



Inox  
Stainless steel  
Nichtrostendern  
Roestvrijstalen  
Inox  
Inox

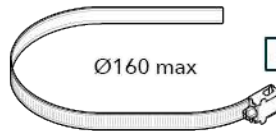

6a

7

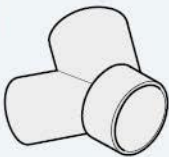

-30°C / +140°C



M1

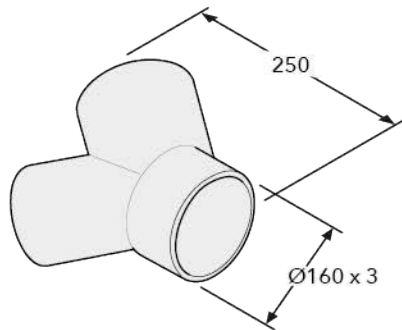

8



Ø160



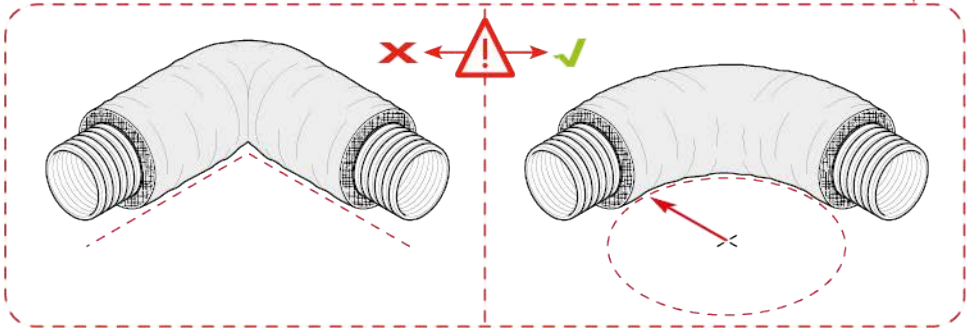
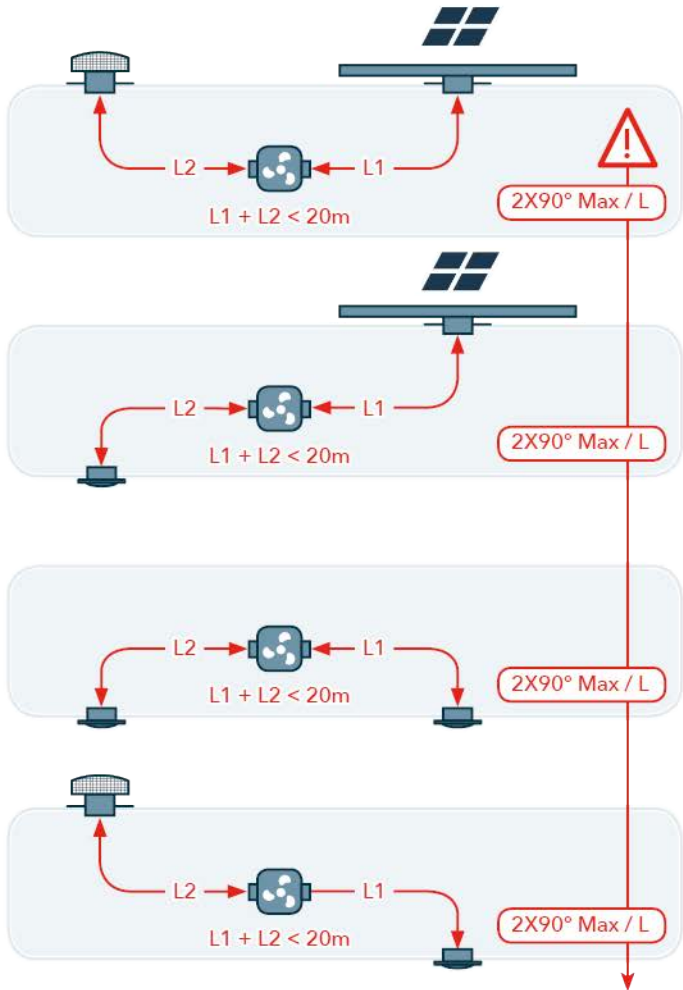
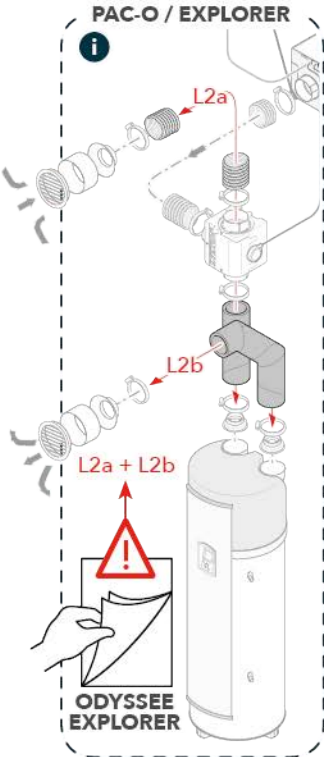
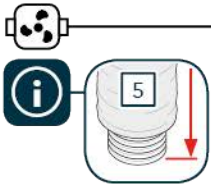



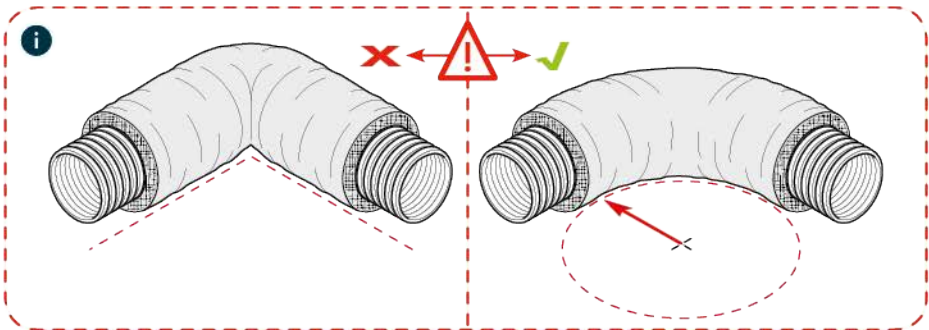
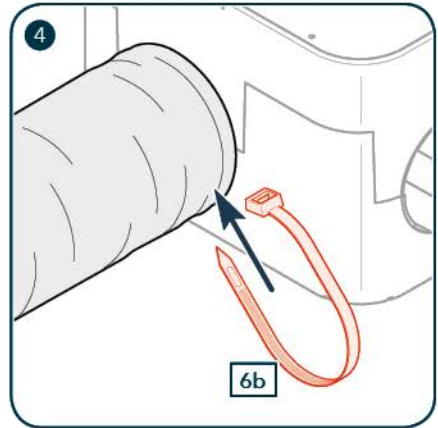
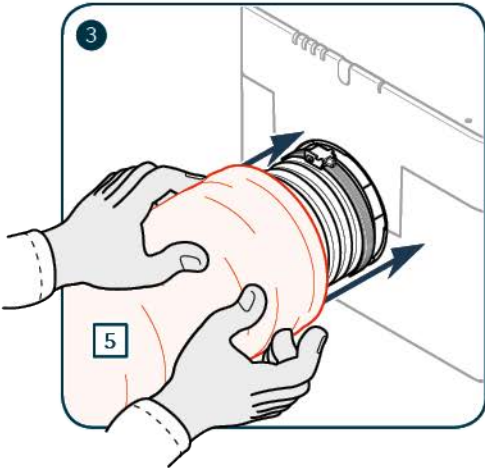
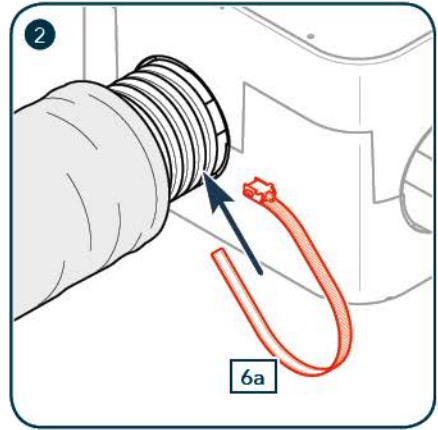
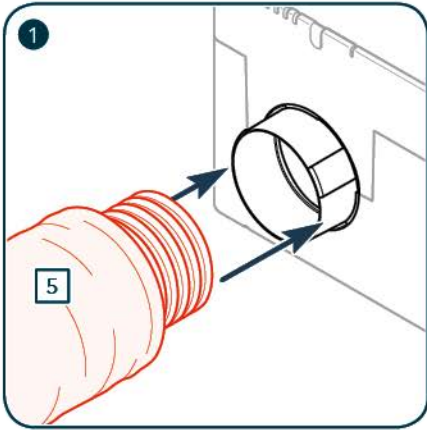



8

9



m <sup>3</sup> /h	m/s	Pa	dB(A)
100	1.74	5	10
200	3.47	17	27
400	6.95	56	44

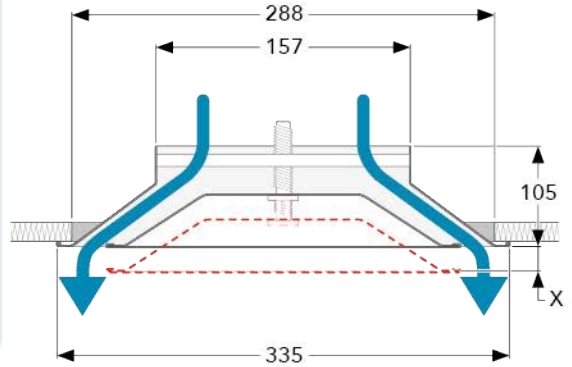

i

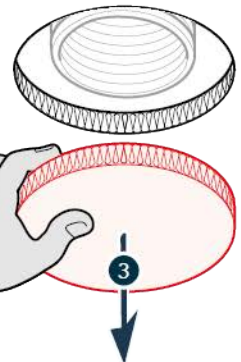
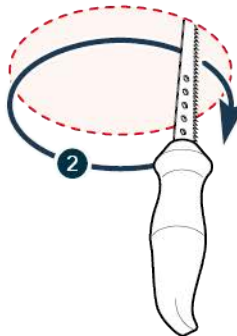
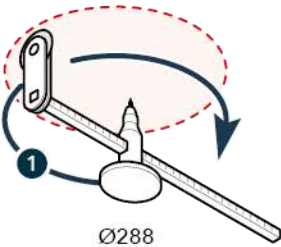
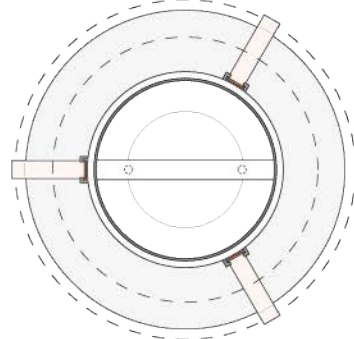
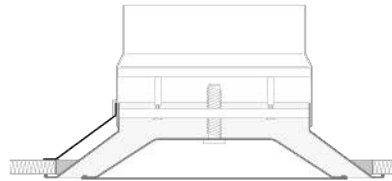
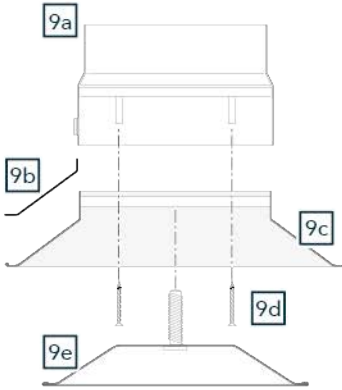

R-VOLT / R-VOLT PLUS  
AIR-VOLT / AIR-VOLT PLUS

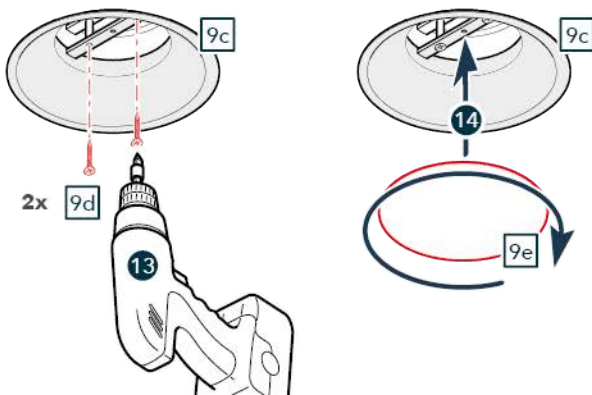
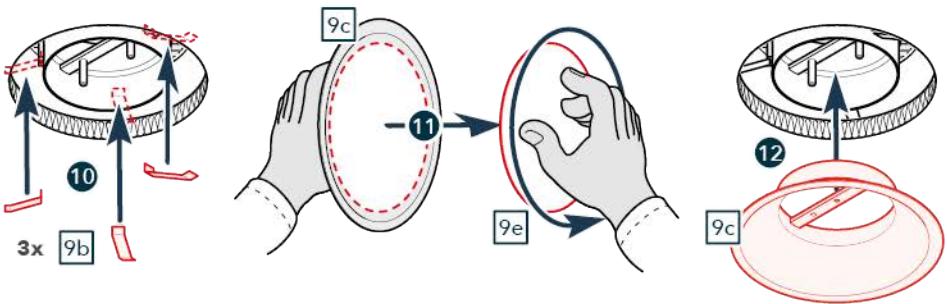
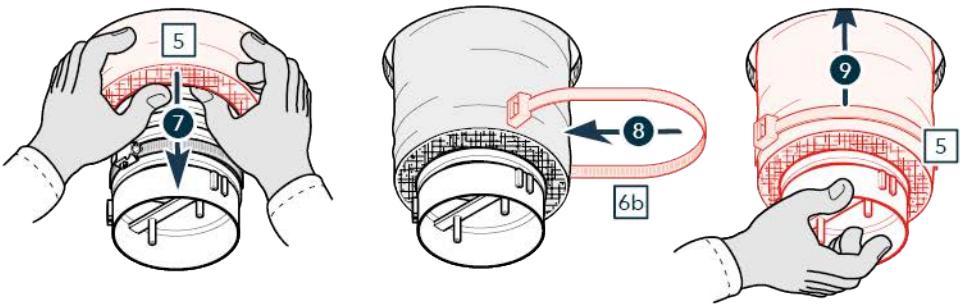
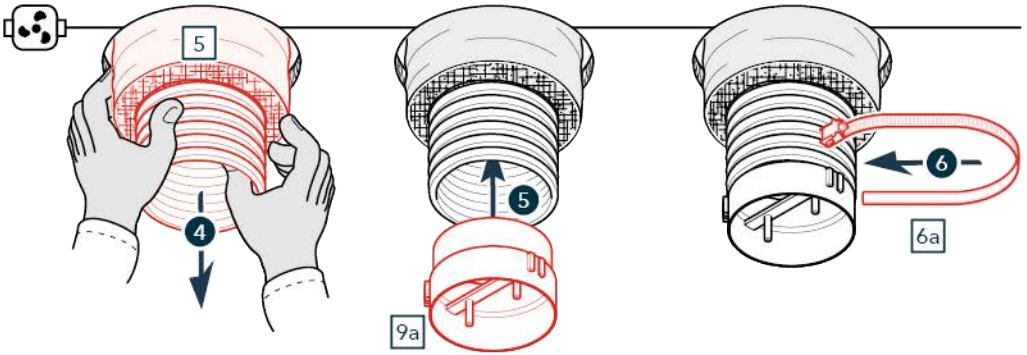



9

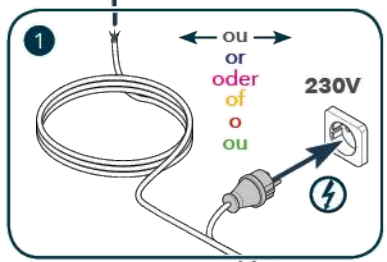
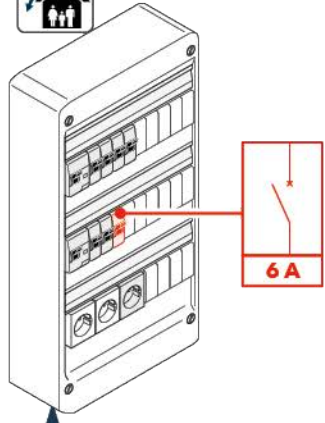
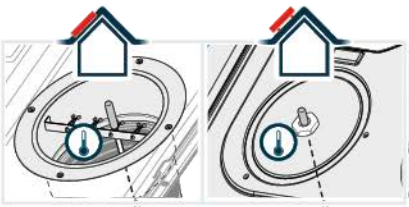
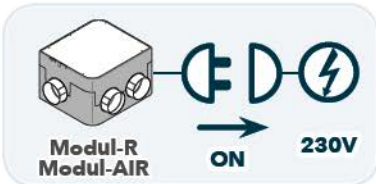

3

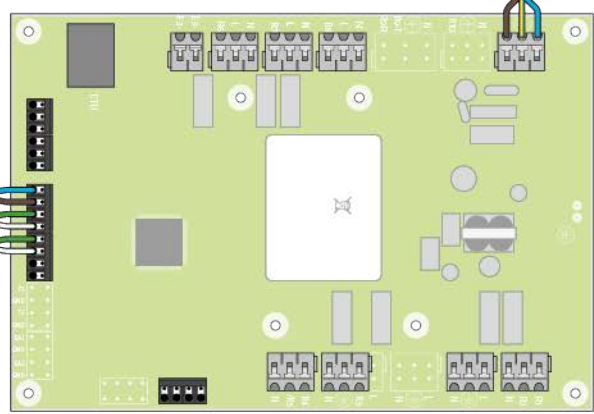
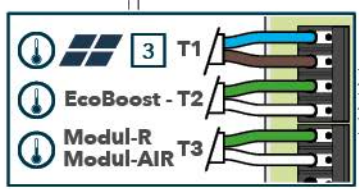

Modu-R / Modu-AIR

 STOCK-R / STORE-H

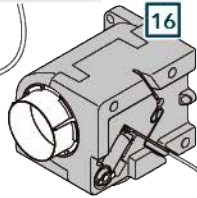
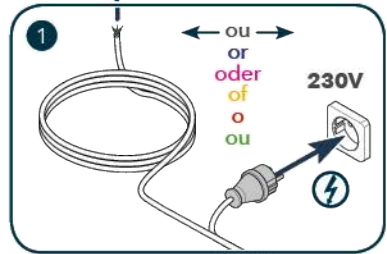
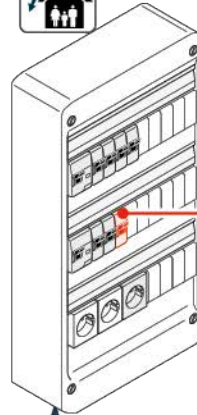
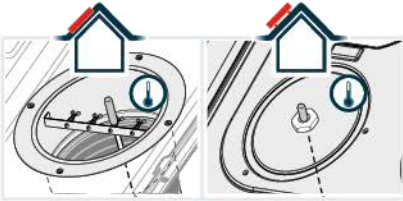
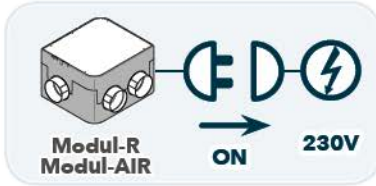

STOCK-R  
STORE-H

11

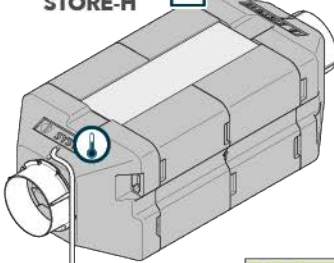

3

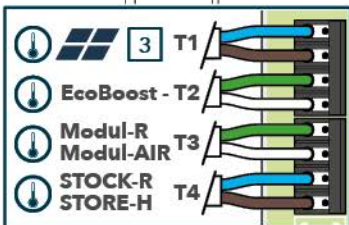

R7

A

230V

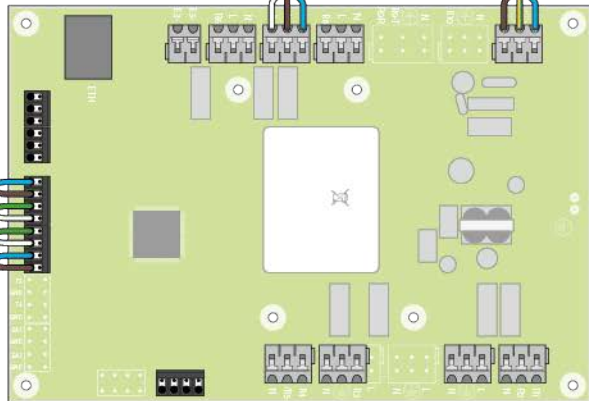

Modu-R / Modu-AIR

 PAC-O / EXPLORER

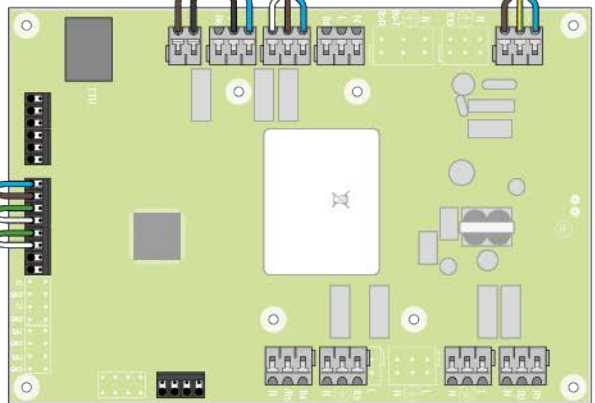
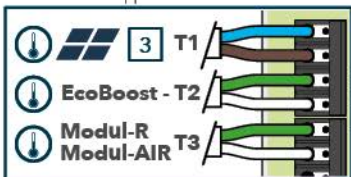
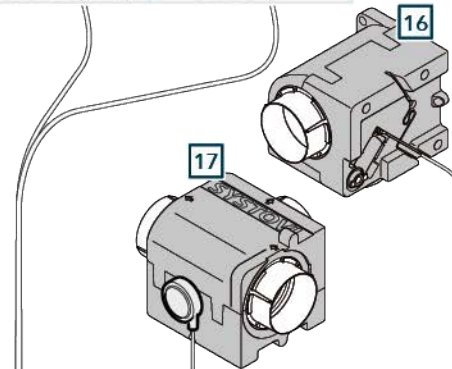
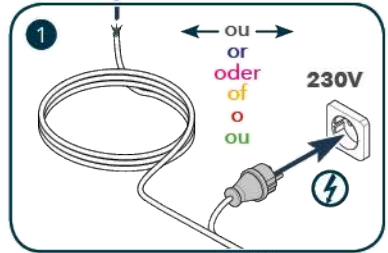
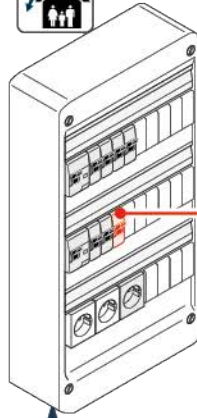
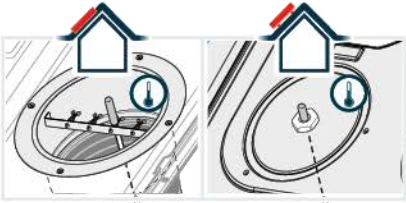
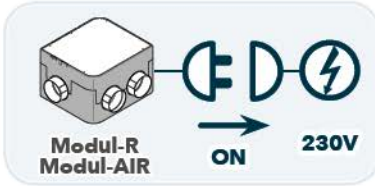

Modu-R / Modu-AIR



10

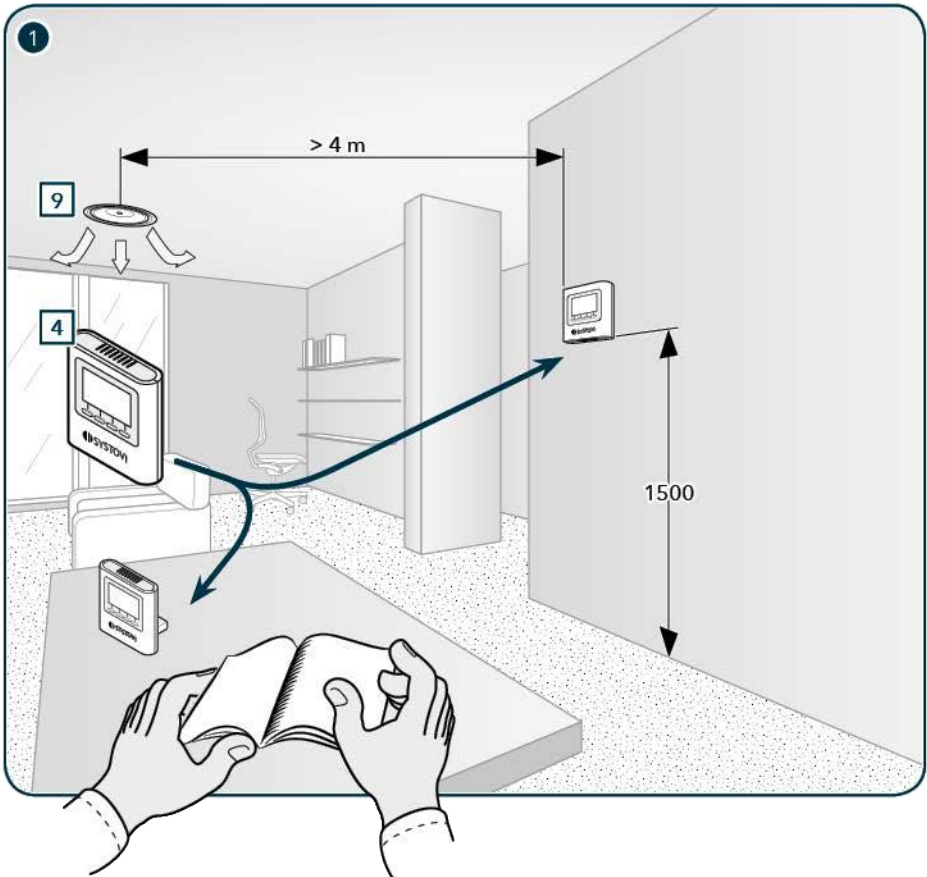
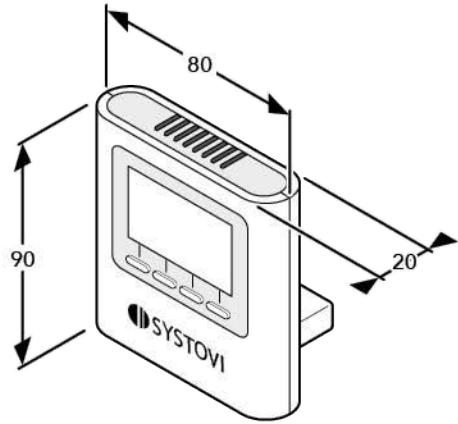
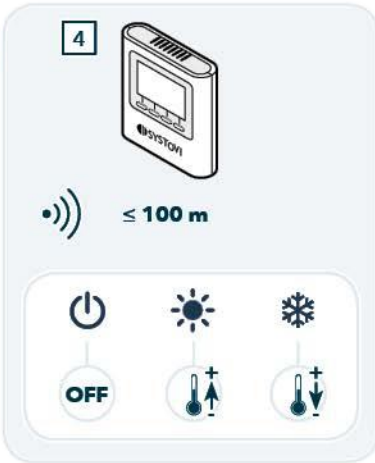



11



Menu installateur  
 Installer menu  
 Monteur-Menü  
 Installateursmenu  
 Menu di installatore  
 Menu de instalador



&



Eveil thermostat - Awakening thermostat - Erwachen Temperaturbegrenzer  
 Ontwaken veiligheidsklaxon - Risveglio termostato - Despertar termostato

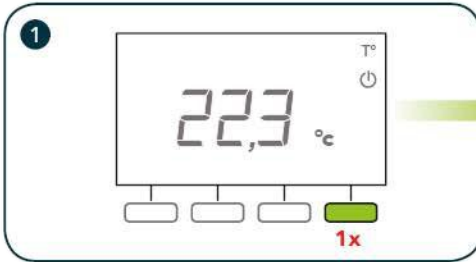

Menu installateur - Installer menu - Monteur-Menü  
 Installateursmenu - Menu di installatore - Menu de instalador

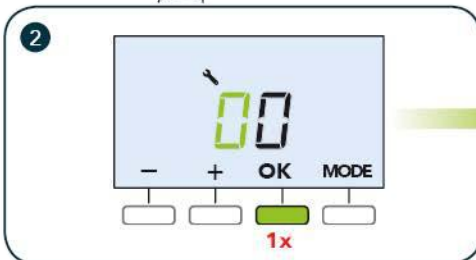
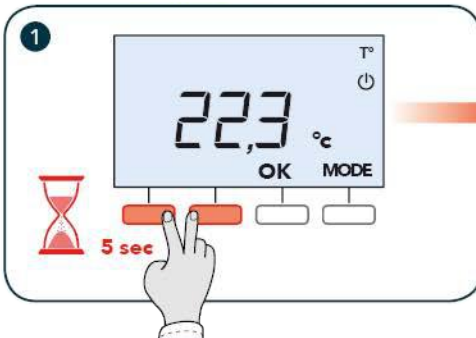

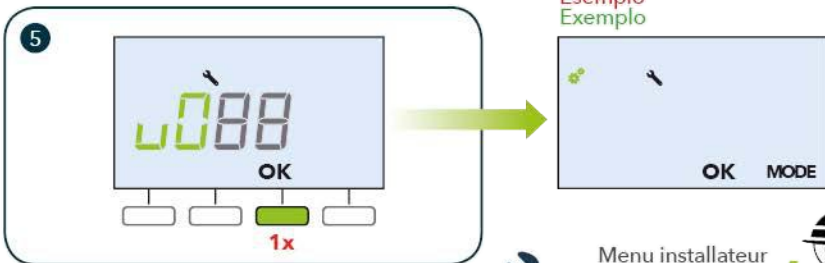
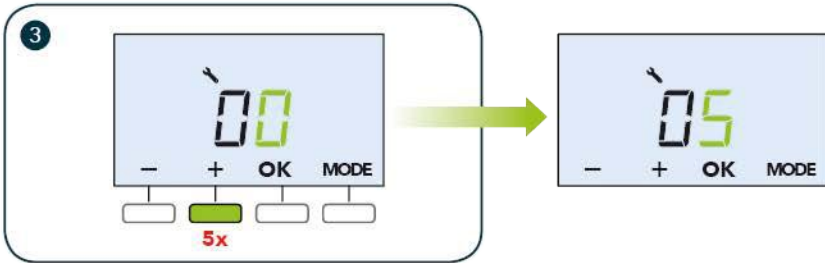

Exemple  
Example  
Beispiel  
Voorbeeld  
Esempio  
Exemplo

025



Menu installateur  
Installer menu  
Monteur-Menü  
Installateursmenu  
Menu di installatore  
Menu de instalador





 Code produit  
 Product code  
 Produktcode  
 Productcode  
 Codice prodotto  
 Código do produto





**Modul-R**  
**Modul-AIR**

**CODE**

4

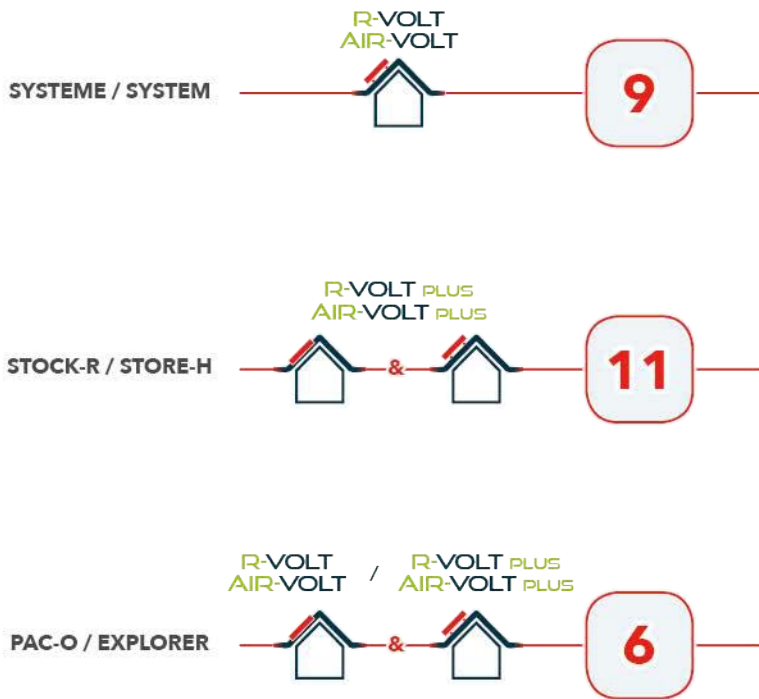

Catégorie : **réglage** - Category : **regulation** - Kategorie : **Einstellung**  
 Categoria : **verordening** - Categoria : **regolazione** - Categoria : **regulamento**

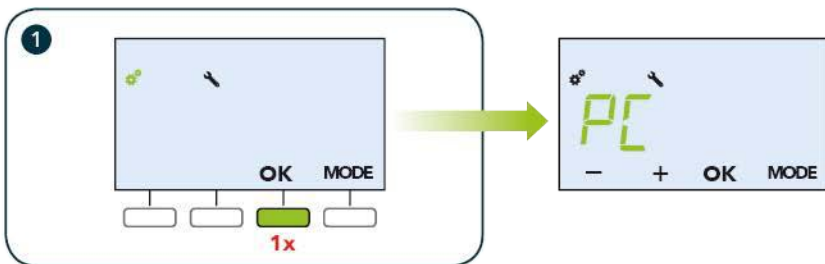

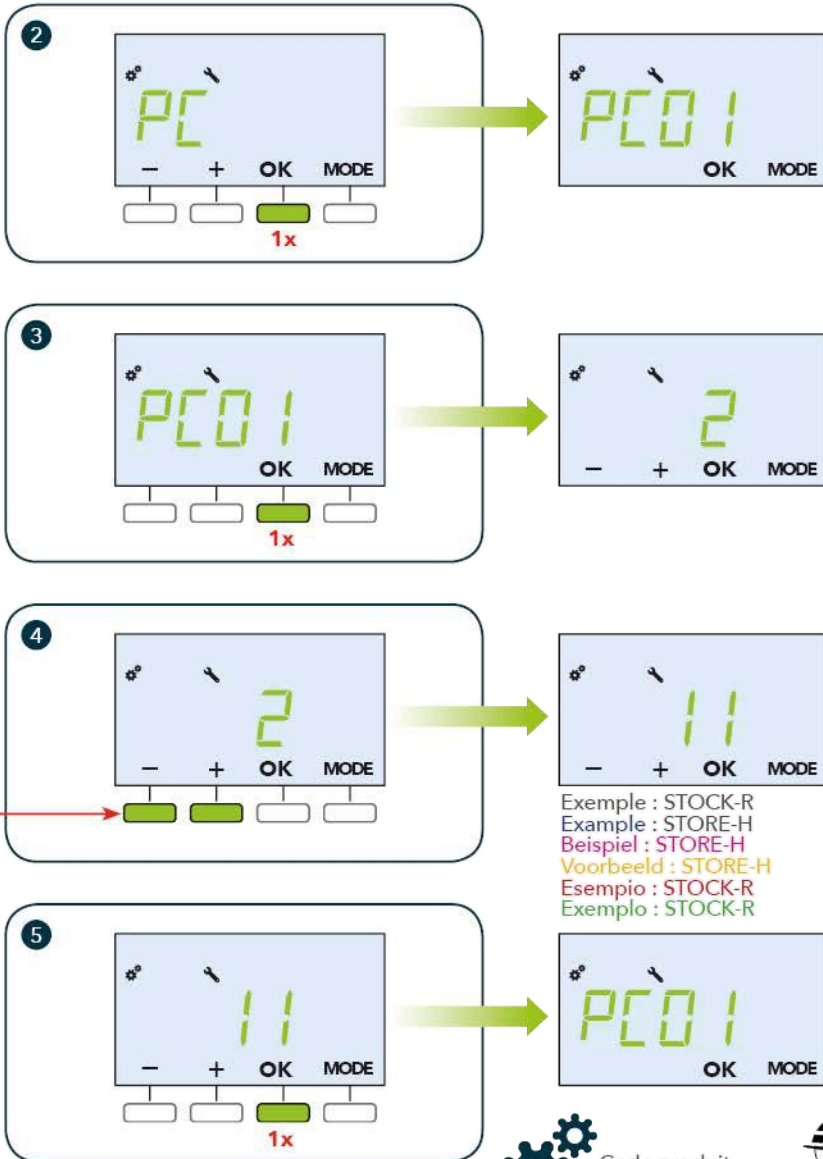

Exemple : STOCK-R  
 Exemple : STORE-H  
 Beispiel : STORE-H  
 Voorbeeld : STORE-H  
 Esempio : STOCK-R  
 Exemplo : STOCK-R



Code produit  
 Product code  
 Produktcode  
 Productcode  
 Codice prodotto  
 Código do produto





12

Test  
 Test  
 Test  
 Test  
 Test  
 Teste

Modul-R  
Modul-AIR

4



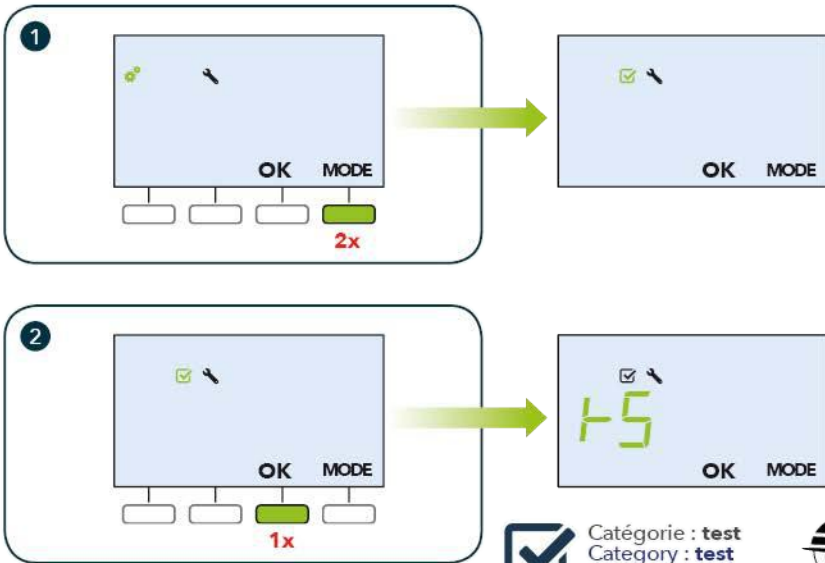

Catégorie : test - Category : test - Kategorie : Test  
 Categoria : test - Categoria : test - Categoria : teste



Catégorie : test  
 Category : test  
 Kategorie : Test  
 Categoria : test  
 Categoria : test  
 Categoria : teste





		4 A SYSTEME SYSTEM	5 B SYSTEME SYSTEM	6 D STOCK-R STORE-H	7 E PAC-O EXPLORER	
1 ✓		✓		✓	✓	52
2 ✓	 EcoBoost	✓	✓	✓	✓	53
3 ✓		✓	✓	✓	✓	54
4 ✓					✓	55
15 ✓				✓		56
16 ✓				✓		57
17 ✓				✓		58
24 ✓	 EcoBoost				✓	59



12

1

400 m<sup>3</sup>/h

R-VOLT AIR-VOLT / R-VOLT PLUS AIR-VOLT PLUS

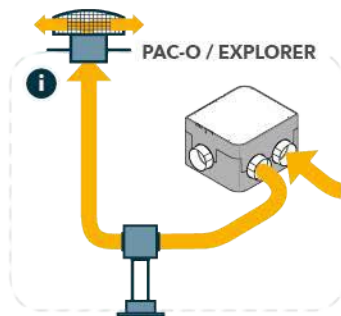
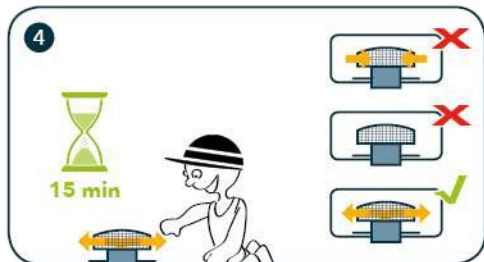
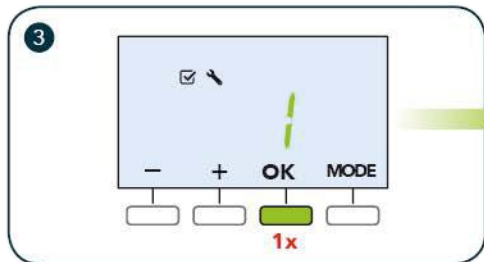
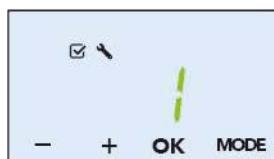
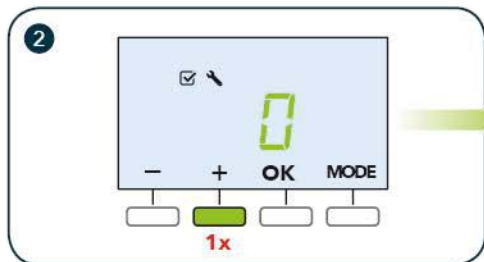
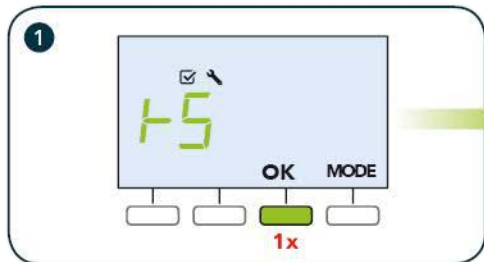
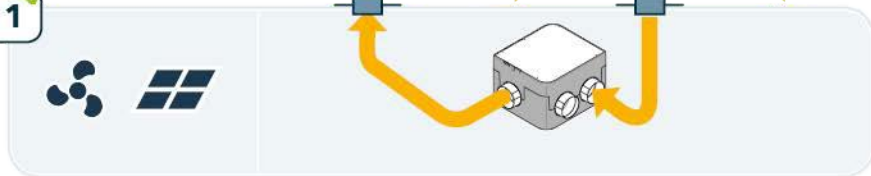



12

2

R-VOLT AIR-VOLT / R-VOLT PLUS AIR-VOLT PLUS

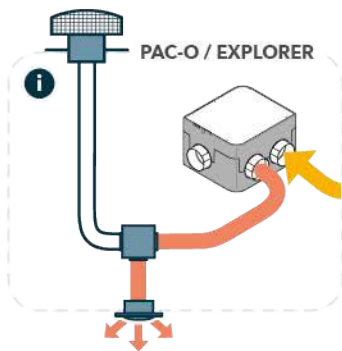
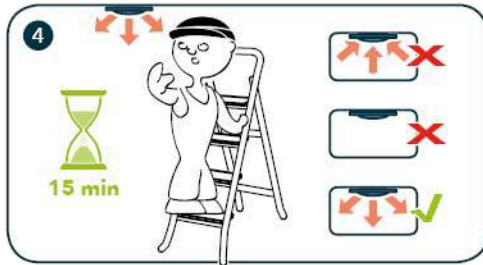
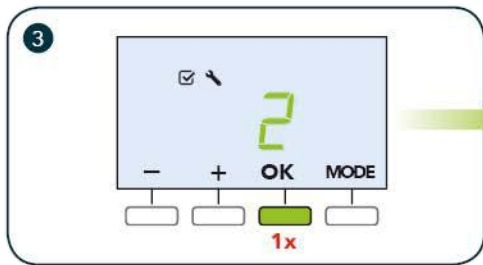
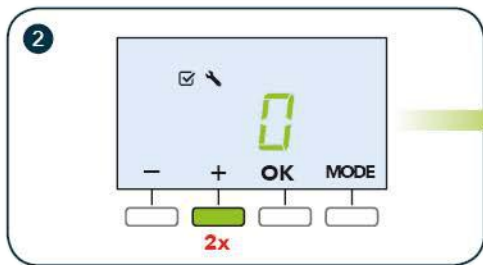
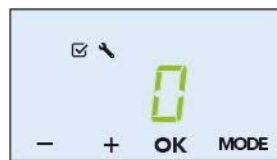
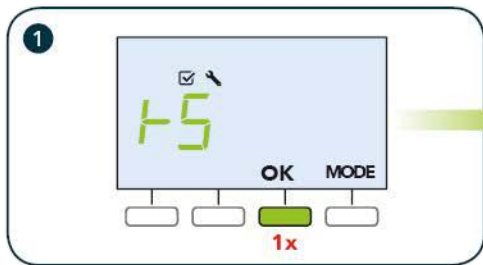
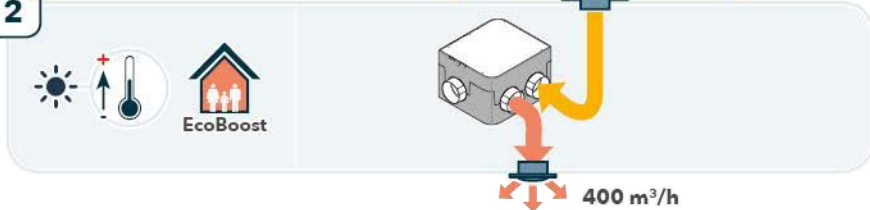



12 3 ✓

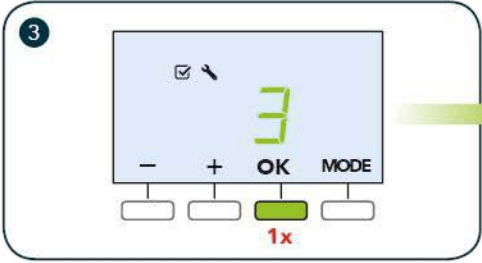
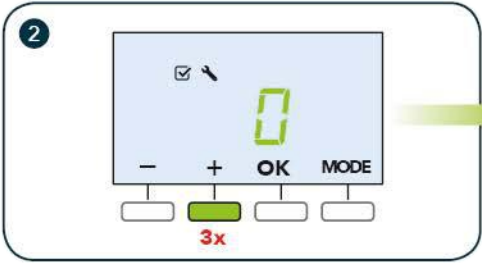
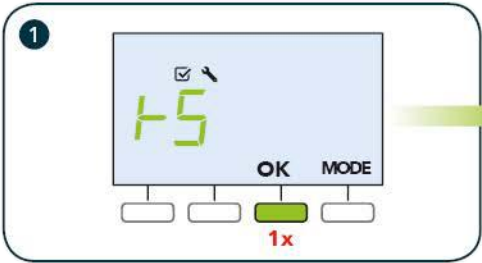
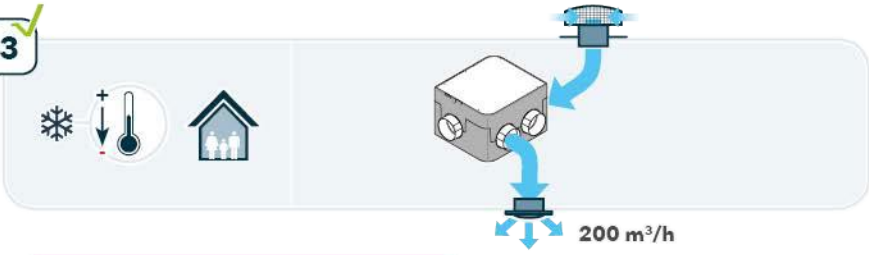



PAC-O / EXPLORER

R-VOLT / R-VOLT PLUS  
AIR-VOLT / AIR-VOLT PLUS

12

4

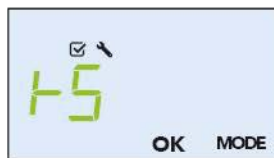
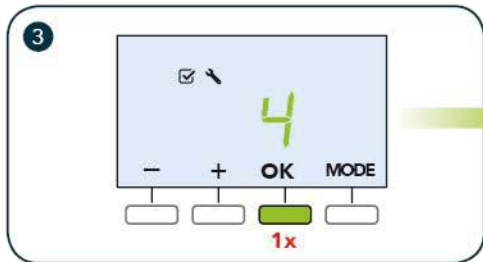
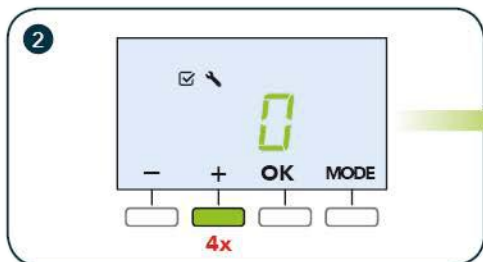
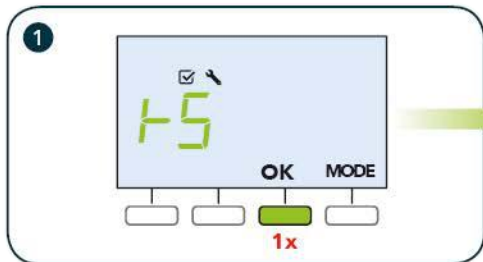
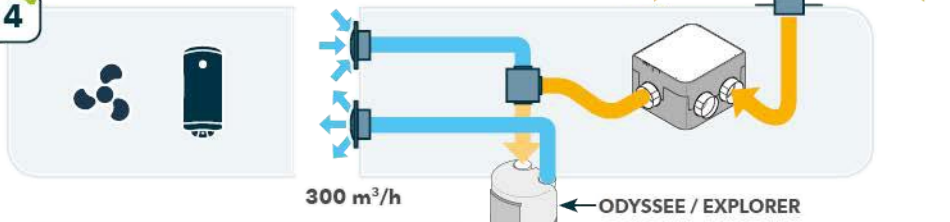



STOCK-R / STORE-H

12

15

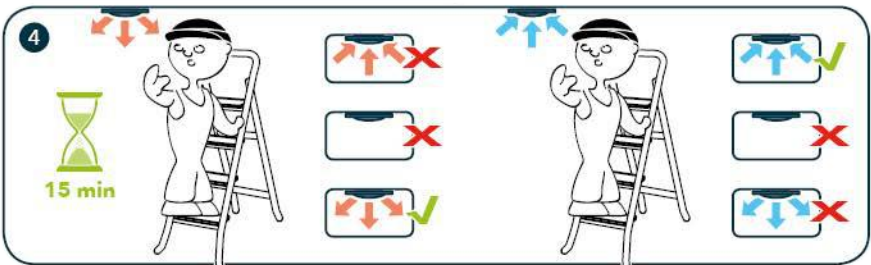
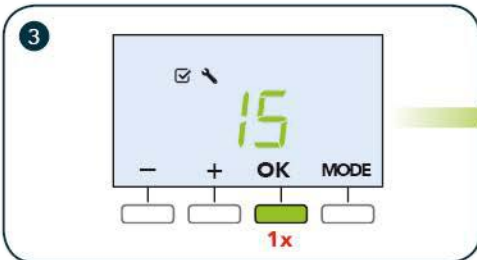
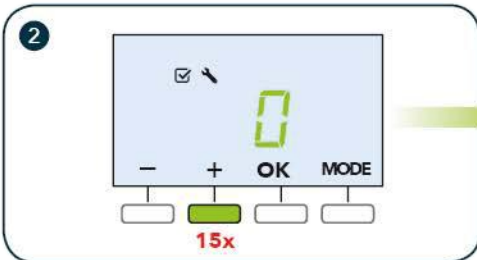
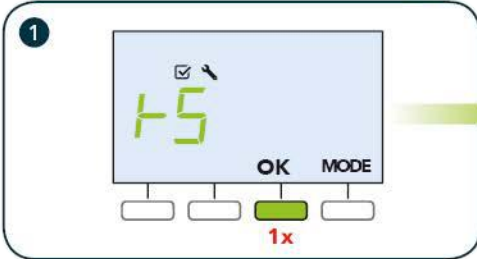
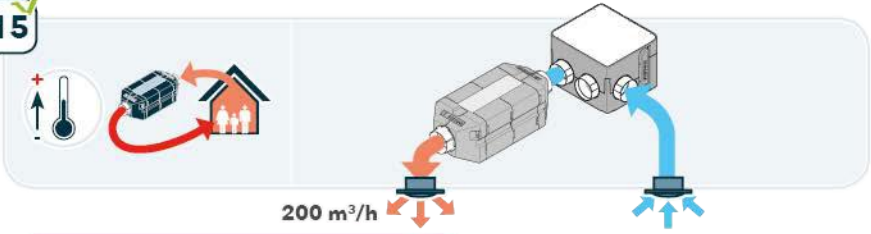

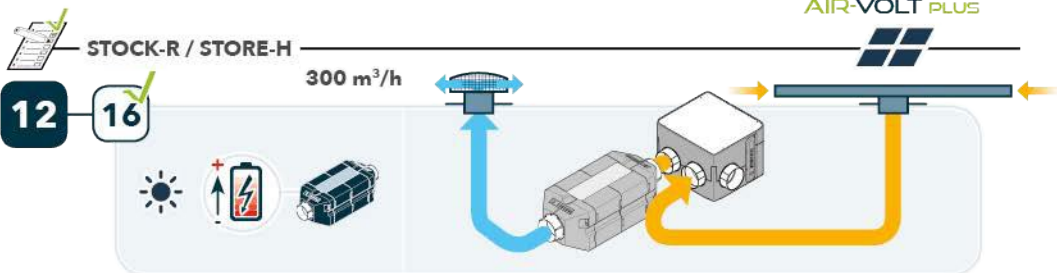

12 16

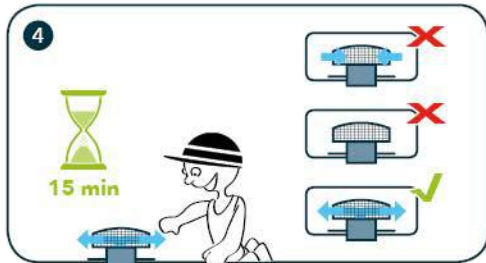
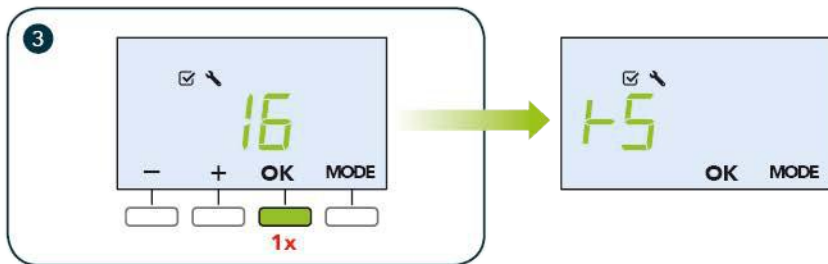
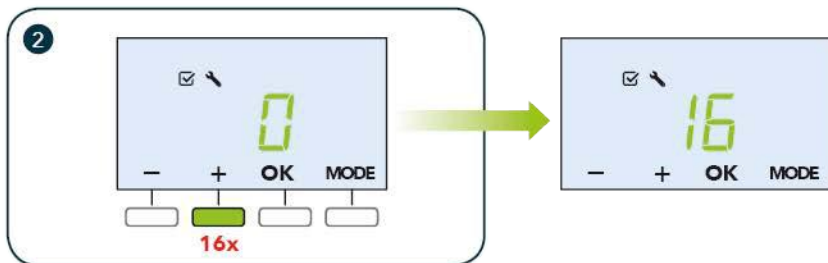
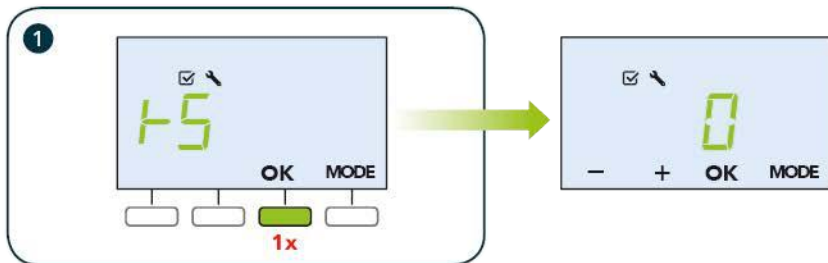



STOCK-R / STORE-H

400 m<sup>3</sup>/h

12 17

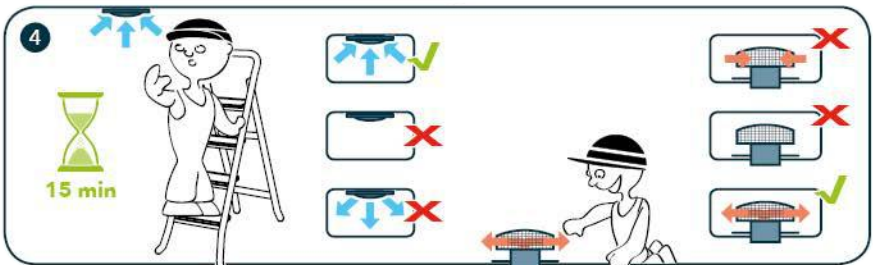
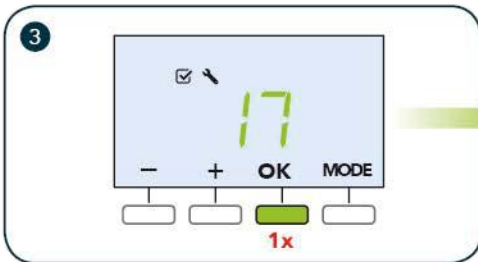
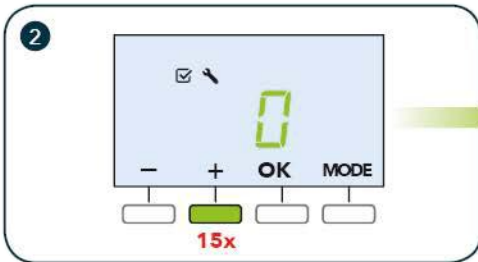
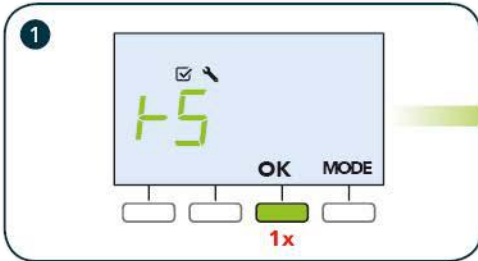
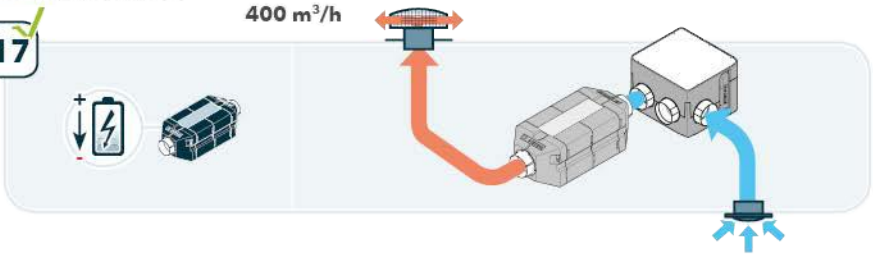



PAC-O / EXPLORER

R-VOLT / AIR-VOLT / R-VOLT PLUS / AIR-VOLT PLUS

12

24

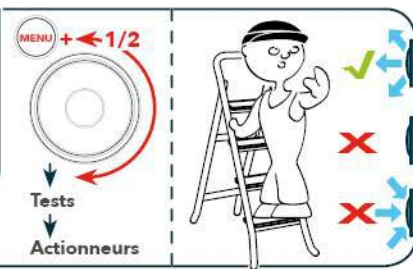
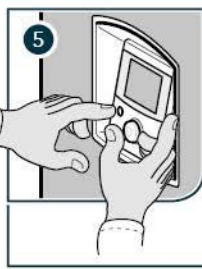
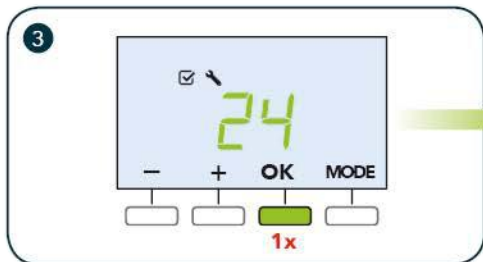
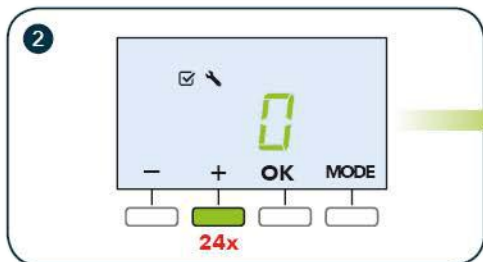
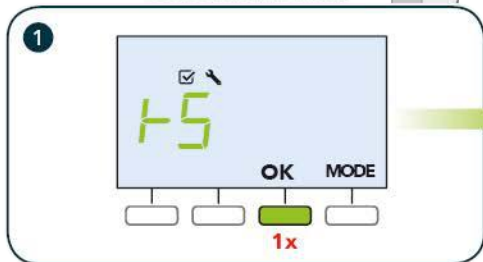
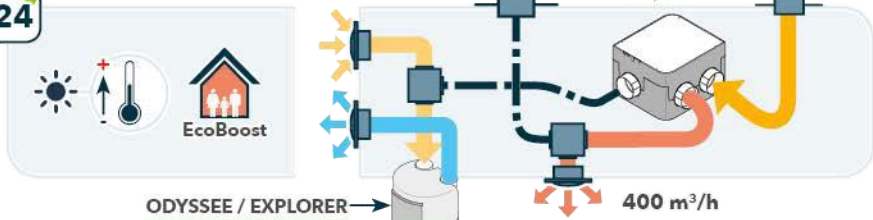



13

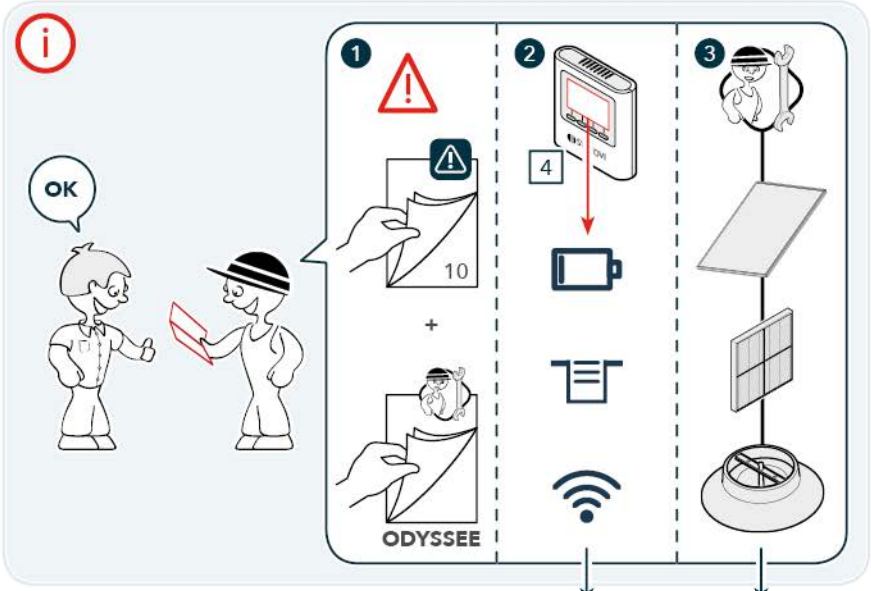

Filtere  
Filter  
Filter  
Filtro  
Filtro

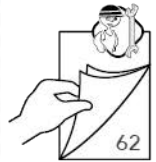
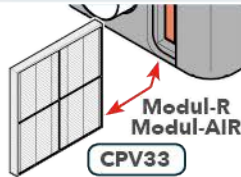

1 an  
1 year  
1 jaar  
1 anno  
1 ano



Batterie  
Battery  
Batterien  
Batterij  
Batterie  
Bateria

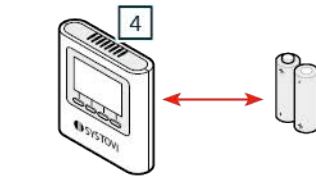

Ondes radio  
Radio wave  
Radiowellen  
Radiogolven  
Onde radio  
Ondas rádio

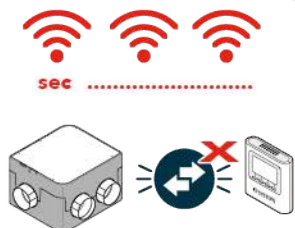
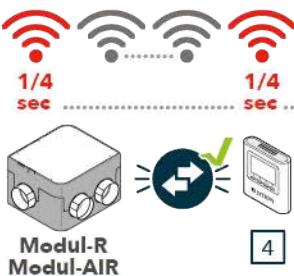



Panneau  
Panel  
Panel  
Pannello  
Painel



1 an  
1 year  
1 Jahr  
1 jaar  
1 anno  
1 ano



Eau  
Water  
Wasser  
Water  
Acqua  
Água

≤ 3 bar

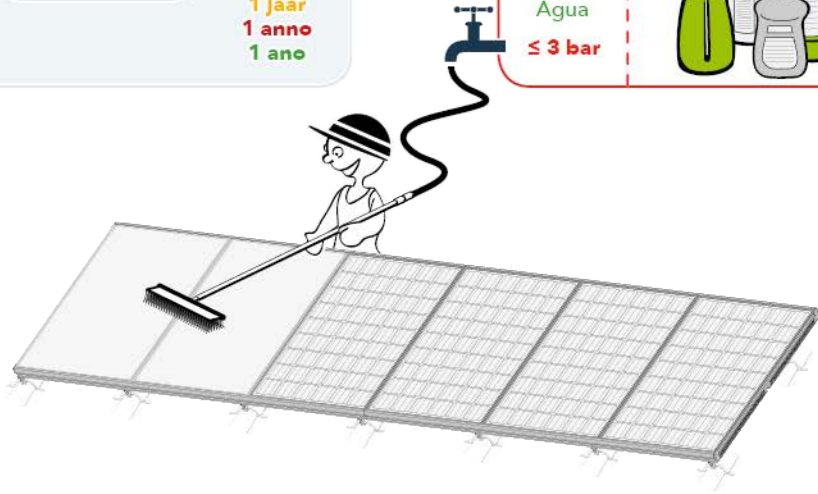

NOUVEAU  
NEW  
NEUEN  
NIEUWE  
NUOVO  
NOVO

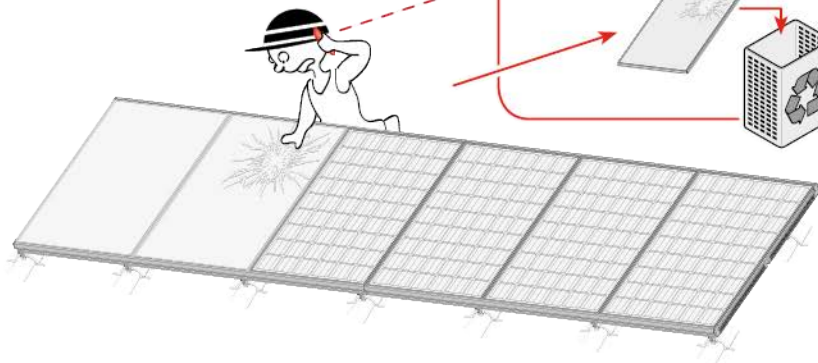
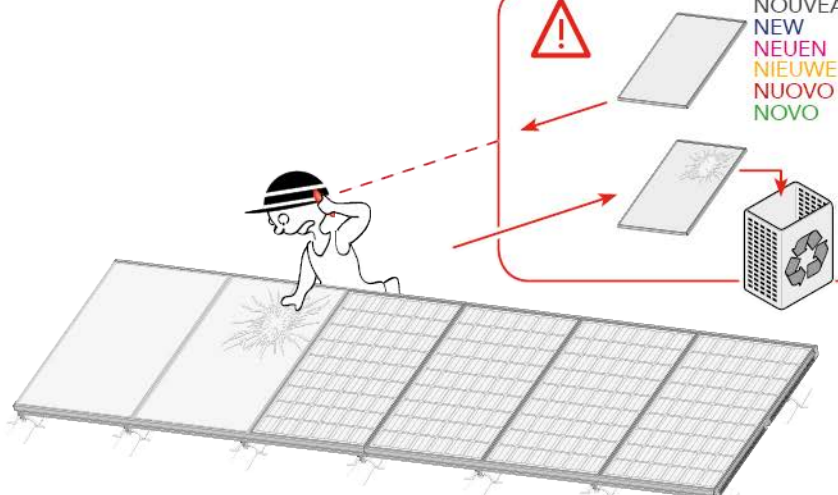

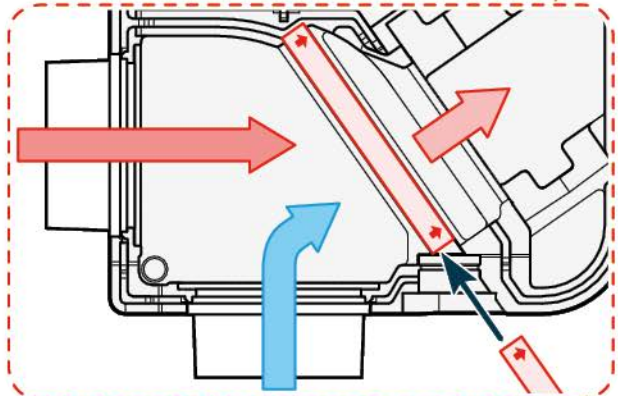
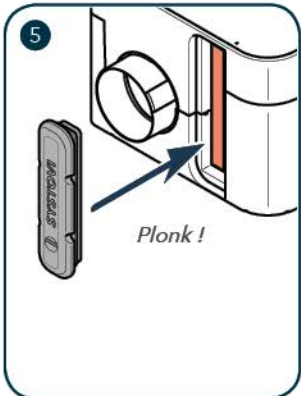
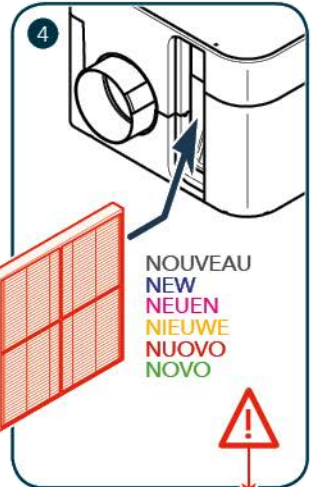
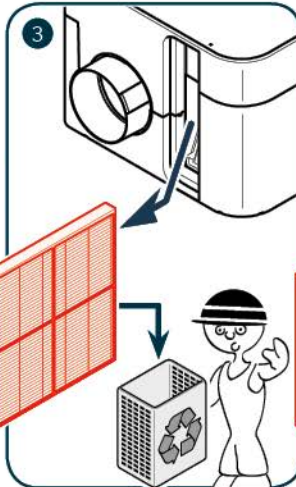
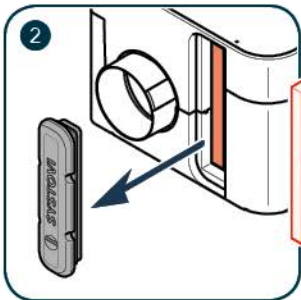
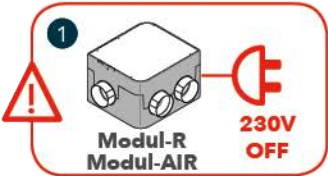
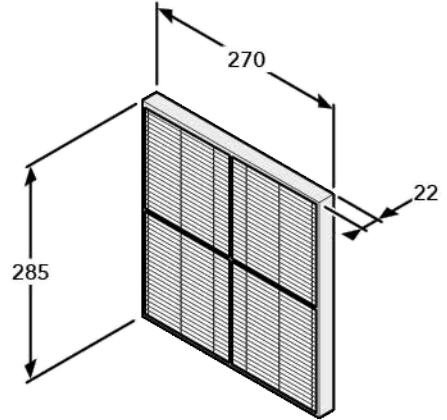
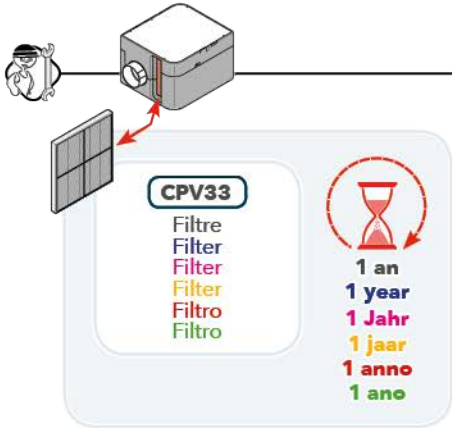



Bouche d'aération  
Air vent  
Luftaustritt  
Luchtrooster  
Canale di scarico  
Conduta de  
ventilação



1 an  
1 year  
1 Jahr  
1 jaar  
1 anno  
1 ano

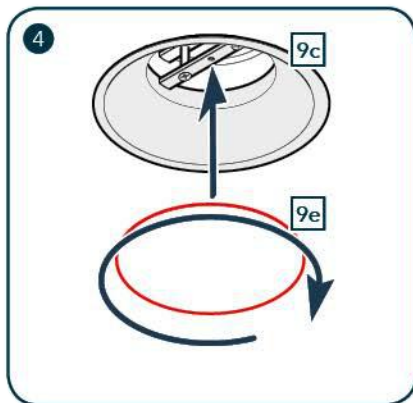
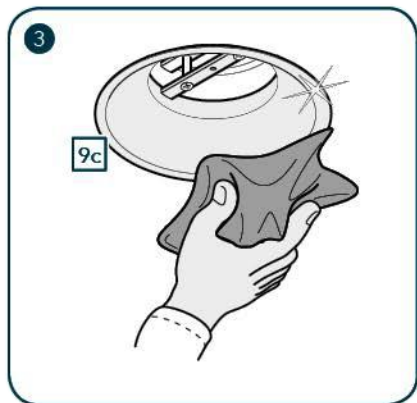
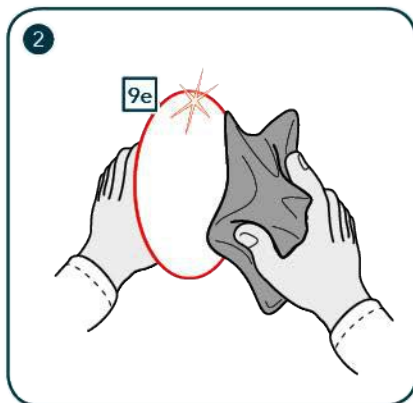
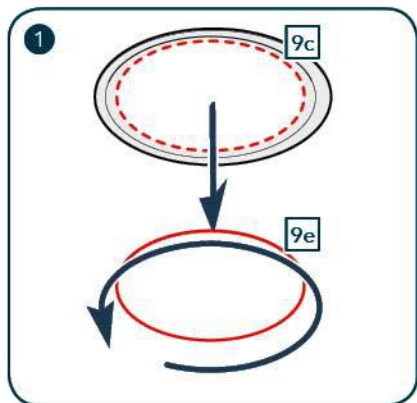

## Assistance technique



Portail SystoPartner  
[www.pro-systovi.com](http://www.pro-systovi.com)  
Rubrique « Support »



[support@systovi.com](mailto:support@systovi.com)



02 40 92 44 20

Obtenez les réponses à  
toutes vos questions techniques



Systovi est un créateur et fabricant français de solutions solaires dédiées à l'habitat. Nos produits sont conçus et fabriqués en France (Saint-Herblain), et distribués dans toute l'Europe.

5 rue du Chêne Lassé  
44 800 Saint-Herblain  
FRANCE  
02 40 92 44 20

[support@systovi.com](mailto:support@systovi.com)  
[www.systovi.com](http://www.systovi.com)

# SYSTÈME AÉRAULIQUE



BN76

